

# Brushless DC Motors

## EnduraMax 95s Series Brushless Motor with Integral Drive

95 mm (3.77-inch) BLDC Motor with Integrated Sensorless Digital Drive

Allied Motion's Gen III EnduraMax 95s series motors are 95 mm (3.77 in) diameter brushless DC motors that incorporate integrated drive electronics. Patented, sensorless drive technology in the E95s enables variable or fixed speed operation for such applications as blowers, fans, compressors, conveyors, pumps, and similar commercial/industrial applications.

EnduraMax 95s motors are highly cost-effective, compact, and have high power density. The integrated sensorless drive module is contained in a housing that conforms with the diameter of the motor for easier fitting in tight space claims.

Compared to brush DC motors, the EnduraMax 95s is quieter, has much longer service life, and needs no maintenance, making it the right choice to replace DC motors in equipment modernizations and in new designs.

Standard EnduraMax 95s winding voltage choices are 12, 24 and 48 VDC, making these motor-drives particularly suited for battery-fed applications. (Alternate winding voltages available via special order.) The E95s provides continuous shaft power up to a nominal 360 W and rated torque of up to 1.7 Nm.

As with all Allied Motion products, custom designs can be provided to exactly match application requirements.

### Features & Benefits

- Three standard frame lengths with rated, continuous output power up to 360 W
- 12, 24 or 48 VDC winding voltage selections – ideal for battery-powered applications
- Continuous rated torque of up to 1.7 Nm (240 oz-in) and rated speed of up to 4900 RPM
- Wide 20:1 speed control range

- All-digital integrated drive electronics module simplifies wiring
- 0 - 10 V standard analog speed command input
- I/O: 1 direction input and 1 speed/status output
- Externally visible status LED
- 0.5-inch (12.7 mm) cold-rolled steel shaft
- Heavy-duty ball bearings
- Drive electronics protection, including reverse voltage
- IP50 protection level
- Automotive-class drive system protection (over-voltage, voltage reversal)
- Class F (155 °C) rated winding

### Options & Accessories

- Non-isolated, J1939 CAN with a custom or Allied Motion's standard J1939 protocol
- Low power drive "sleep" mode (available with CAN option only)
- 2-wire version—control the EnduraMax like a DC motor
- PWM speed control
- Potentiometer speed control
- Tailored winding designs to optimize performance
- Customized analog command input voltage ranges
- Sealed ball bearings
- Stainless steel shaft
- IP65 protection level
- Customized shaft, and/or mounting to match application requirements
- Alternate winding voltages available via special order
- Motor winding over-temperature protection
- Sinking and sourcing inputs
- Separate motor-enable input



- Brushless DC motor with integrated patented drive for torque or speed control applications
- Rated speed up to 4900 RPM with 20:1 speed control range
- Continuous output of up to 360 W and 1.7 Nm

# Brushless DC Motors

## EnduraMax 95s Series Brushless Motor with Integral Drive

### SPECIFICATIONS (2-STACK MODELS)

	EMS-095Q2008	EMS-095Q2012	EMS-095R2009	EMS-095R2010	EMS-095G2009	EMS-095G2010
	Low Speed	High Speed	Low Speed	High Speed	Low Speed	High Speed
DC Input Voltage [VDC ± 15%]	12		24		48	
Rated Cont. Torque [Nm (oz-in)]	0.46 (66)	0.28 (40)	0.64 (91)	0.39 (56)	0.71 (101)	0.53 (75)
Peak Torque [Nm (oz-in)] <sup>(1)</sup>	0.85 (120)	0.60 (85)	1.84 (260)	1.41 (200)	2.11 (300)	2.05 (290)
Rated Speed [RPM]	2850	4900	2500	4700	2400	4600
No-load Speed [RPM]	3500	5500	3250	5300	3100	5400
Rated Cont. Power [W (HP)] <sup>(2)</sup>	140 (0.19)	150 (0.20)	175 (0.23)	200 (0.27)	180 (0.24)	260 (0.35)
DC Input Current [ADC]	16.1	17.2	10.4	11.0	5.3	7.6
Power Derating Above 23°C [W/°C (W/°F)]	1.15 (0.64)	3.03 (1.69)	1.22 (0.68)	1.64 (0.91)	1.20 (0.67)	1.87 (1.04)
Motor Rotor Inertia [E-5 kg-m <sup>2</sup> (oz-in-sec <sup>2</sup> )]	6.10 (0.0086)					
Weight [kg (lb)]	1.33 (2.93)					
Available Control Modes	Open-loop speed control "OLV" mode (standard), current mode, and velocity mode					
Amplifier Type	PWM (20 kHz) 4-quadrant control					
Current (Torque) Loop Type	DQ PI, 100 μs update time					
Velocity Loop	PID / PDF 200 μs update time					
Standard Analog Input	0 to +10.0 VDC, 10kΩ, 12-bit resolution					
Standard Digital I/O	<ul style="list-style-type: none"> <li>Reverse direction input: +3 to +60 V (high); 0 to +0.5 V (low) at 3 mA nominal draw, sourcing</li> <li>Speed/status output: open collector, +60 V max., 100 mA max. sink</li> </ul>					
Speed / Status Output	<ul style="list-style-type: none"> <li>Speed monitor: 9 pulses per motor revolution</li> <li>Drive over-temperature fault: 25% duty-cycle at 10 Hz</li> <li>Bus under-voltage or over-voltage fault: 50% duty-cycle at 10 Hz</li> <li>Stall or short-circuit fault: 75% duty cycle at 10 Hz</li> </ul>			<ul style="list-style-type: none"> <li>Other fault: 100% duty cycle</li> <li>Disabled: 0 V (nominal) output</li> <li>Externally visible status LED notifies user of motor condition</li> </ul>		
Standard Protection Features	<ul style="list-style-type: none"> <li>I<sup>2</sup>T current foldback</li> <li>Over-voltage detect<sup>(3)</sup></li> <li>Short-circuit protect</li> </ul>		<ul style="list-style-type: none"> <li>Reverse polarity protect</li> <li>Load dump protect</li> <li>Drive over-temperature protect</li> </ul>		<ul style="list-style-type: none"> <li>IP50 protect level</li> <li>Locked rotor protect (disable after three failed start attempts)</li> </ul>	
Optional Drive Configuration Features (Contact Allied Motion for Details)	<ul style="list-style-type: none"> <li>Customized analog command input voltage ranges</li> <li>Motor winding over-temperature protect</li> </ul>		<ul style="list-style-type: none"> <li>Sinking and sourcing inputs</li> <li>Separate motor-enable input</li> <li>IP65 protection level</li> <li>2-wire input</li> </ul>		<ul style="list-style-type: none"> <li>PWM speed control</li> <li>Non-isolated, J1939 CAN input<sup>(4)</sup></li> <li>Potentiometer speed control</li> <li>And more...</li> </ul>	
Ambient Storage Temperature	-40 to 125 °C (-40 to 257 °F)					

(1) Maximum of 4 sec.

(2) With motor mounted to aluminum plate 200 x 200 x 10 mm (8 x 8 x 0.375 in) at 23 °C (derate motor power above 23 °C ambient temperature)

(3) The user is responsible for checking the details of their power source to determine its ability to accept regenerated energy if produced by the user's system

(4) The user is responsible for providing CAN isolation if required by the user's system. Available with custom or Allied Motion's standard J1939 protocol

### PERFORMANCE (2-STACK MODELS)

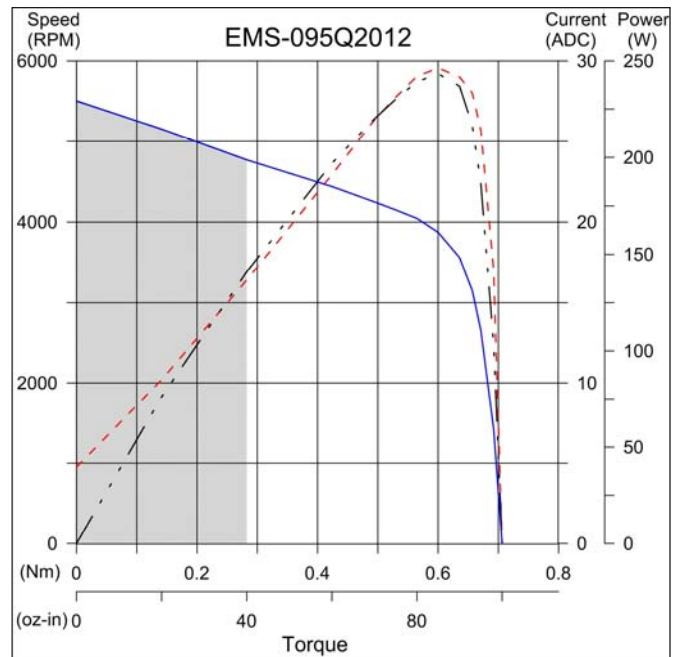
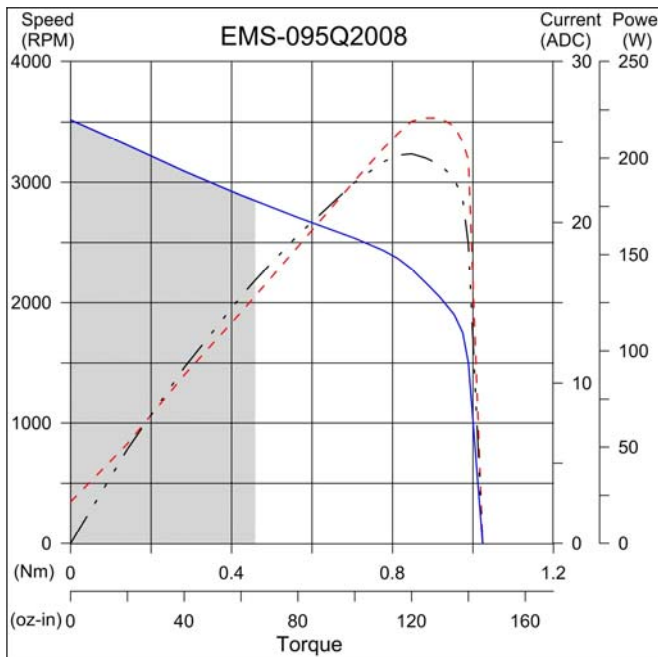

# Brushless DC Motors

## EnduraMax 95s Series Brushless Motor with Integral Drive

### PERFORMANCE (2-STACK MODELS)

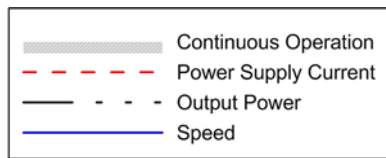
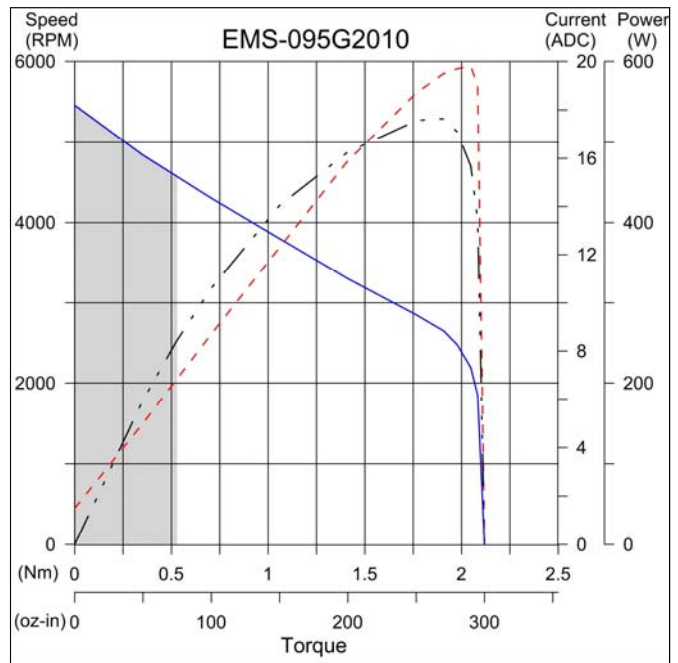
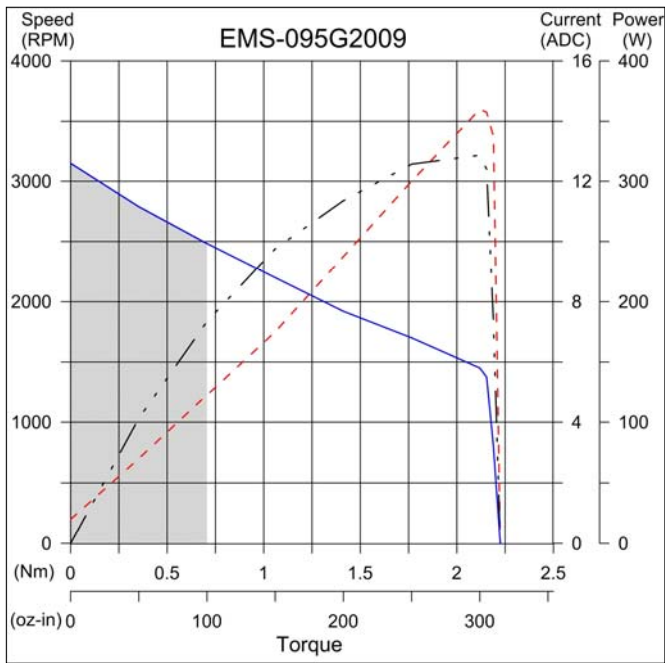
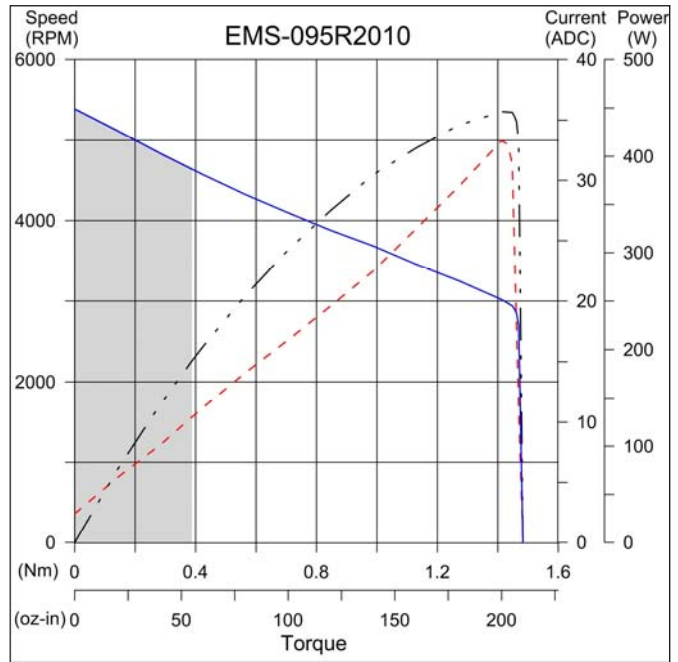
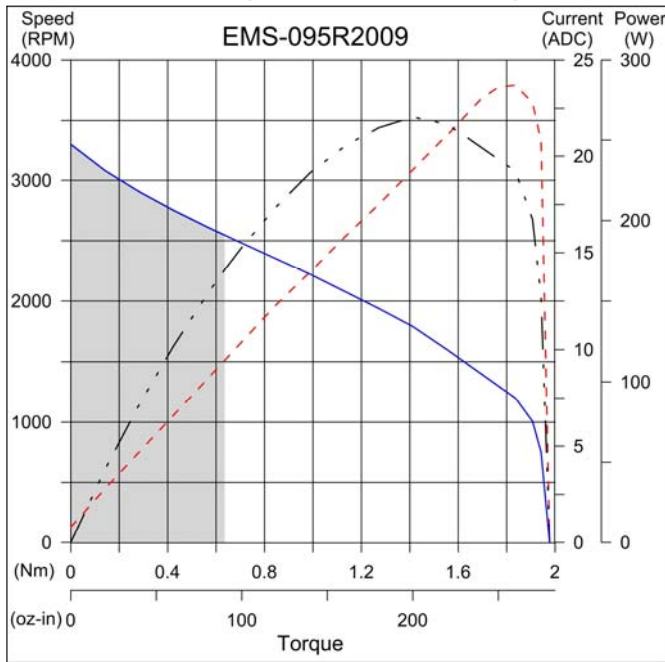

# Brushless DC Motors

## EnduraMax 95s Series Brushless Motor with Integral Drive

### SPECIFICATIONS (6-STACK MODELS)

	EMS-095Q6011	EMS-095Q6014	EMS-095R6012	EMS-095R6013	EMS-095G6012	EMS-095G6013
	Low Speed	High Speed	Low Speed	High Speed	Low Speed	High Speed
DC Input Voltage [VDC ± 15%]	12		24		48	
Rated Cont. Torque [Nm (oz-in)]	0.77 (110)	0.42 (60)	1.10 (157)	0.60 (85)	1.13 (161)	0.71 (101)
Peak Torque [Nm (oz-in)] <sup>(1)</sup>	1.41 (200)	0.85 (120)	2.90 (410)	1.34 (190)	2.97 (420)	2.68 (380)
Rated Speed [RPM]	1900	3850	1650	3850	2100	4000
No-load Speed [RPM]	2250	4150	2100	4200	2600	4350
Rated Cont. Power [W (HP)] <sup>(2)</sup>	155 (0.21)	170 (0.23)	195 (0.26)	255 (0.34)	260 (0.35)	300 (0.40)
DC Input Current [ADC]	17.2	18.9	11.0	13.8	6.9	7.7
Power Derating Above 23°C [W/°C (W/°F)]	1.17 (0.65)	2.73 (1.52)	1.26 (0.70)	2.61 (1.45)	1.98 (1.10)	3.84 (2.14)
Motor Rotor Inertia [E-4 kg-m <sup>2</sup> (oz-in-sec <sup>2</sup> )]	1.17 (0.0166)					
Weight [kg (lb)]	1.93 (4.24)					
Available Control Modes	Open-loop speed control "OLV" mode (standard), current mode, and velocity mode					
Amplifier Type	PWM (20 kHz) 4-quadrant control					
Current (Torque) Loop Type	DQ PI, 100 µs update time					
Velocity Loop	PID / PDF 200 µs update time					
Standard Analog Input	0 to +10.0 VDC, 10kΩ, 12-bit resolution					
Standard Digital I/O	<ul style="list-style-type: none"> <li>Reverse direction input: +3 to +60 V (high); 0 to +0.5 V (low) at 3 mA nominal draw, sourcing</li> <li>Speed/status output: open collector, +60 V max., 100 mA max. sink</li> </ul>					
Speed / Status Output	<ul style="list-style-type: none"> <li>Speed monitor: 9 pulses per motor revolution</li> <li>Drive over-temperature fault: 25% duty-cycle at 10 Hz</li> <li>Bus under-voltage or over-voltage fault: 50% duty-cycle at 10 Hz</li> <li>Stall or short-circuit fault: 75% duty cycle at 10 Hz</li> <li>Other fault: 100% duty cycle</li> <li>Disabled: 0 V (nominal) output</li> <li>Externally visible status LED notifies user of motor condition</li> </ul>					
Standard Protection Features	<ul style="list-style-type: none"> <li>I<sup>2</sup>T current foldback</li> <li>Over-voltage detect<sup>(3)</sup></li> <li>Short-circuit protect</li> <li>Reverse polarity protect</li> <li>Load dump protect</li> <li>Drive over-temperature protect</li> <li>IP50 protect level</li> <li>Locked rotor protect (disable after three failed start attempts)</li> </ul>					
Optional Drive Configuration Features (Contact Allied Motion for Details)	<ul style="list-style-type: none"> <li>Customized analog command input voltage ranges</li> <li>Motor winding over-temperature protect</li> <li>Sinking and sourcing inputs</li> <li>Separate motor-enable input</li> <li>IP65 protection level</li> <li>2-wire input</li> <li>PWM speed control</li> <li>Non-isolated, J1939 CAN input<sup>(4)</sup></li> <li>Potentiometer speed control</li> <li>And more...</li> </ul>					
Ambient Storage Temperature	-40 to 125 °C (-40 to 257 °F)					

(1) Maximum of 4 sec.

(2) With motor mounted to aluminum plate 200 x 200 x 10 mm (8 x 8 x 0.375 in) at 23 °C (derate motor power above 23 °C ambient temperature)

(3) The user is responsible for checking the details of their power source to determine its ability to accept regenerated energy if produced by the user's system

(4) The user is responsible for providing CAN isolation if required by the user's system. Available with custom or Allied Motion's standard J1939 protocol

### PERFORMANCE (6-STACK MODELS)

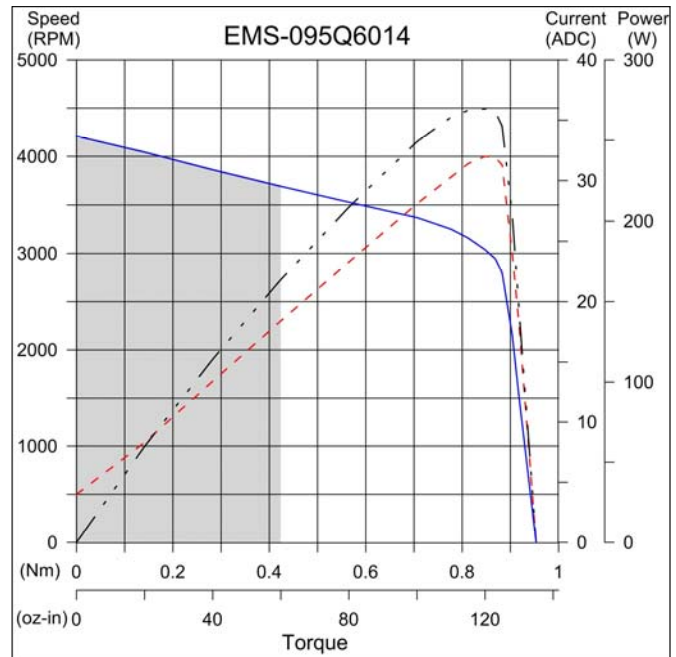
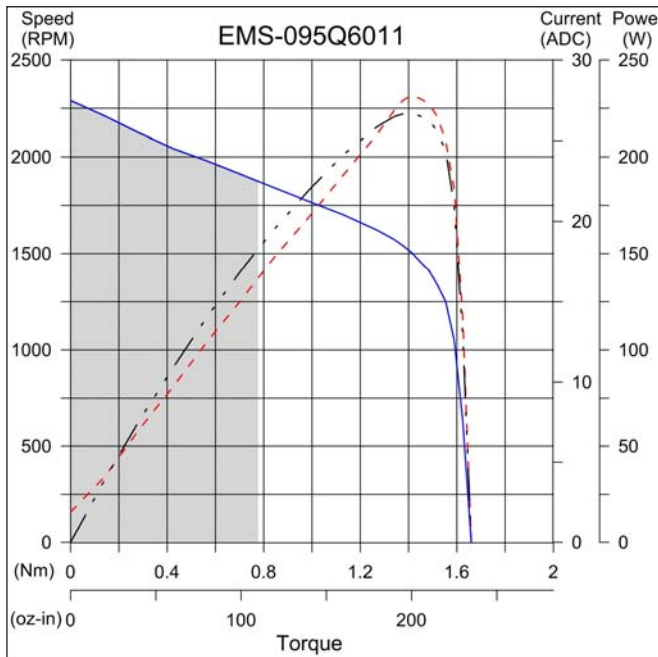



# Brushless DC Motors

## EnduraMax 95s Series Brushless Motor with Integral Drive

### PERFORMANCE (6-STACK MODELS)

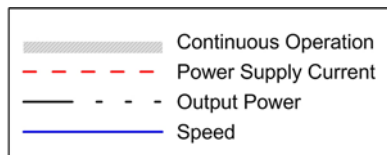
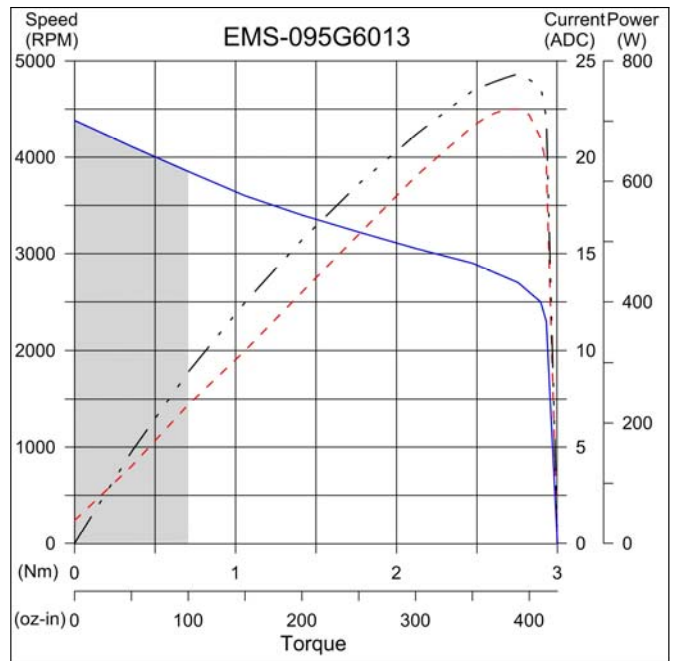
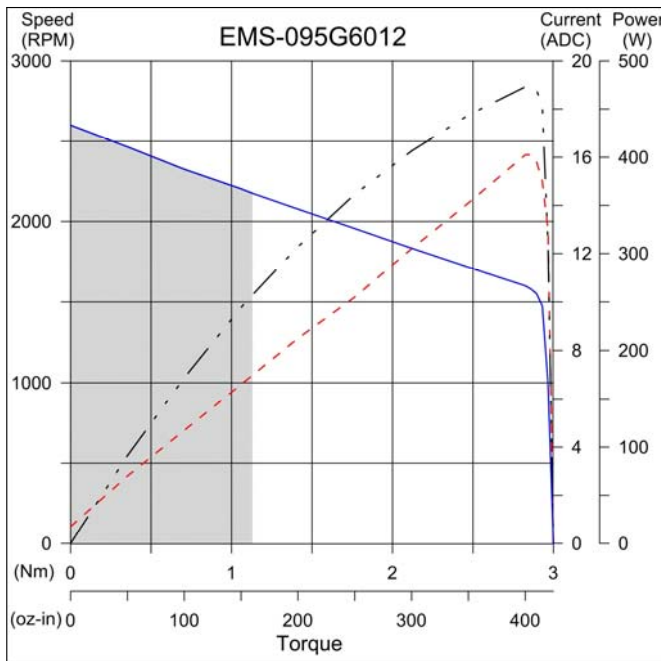
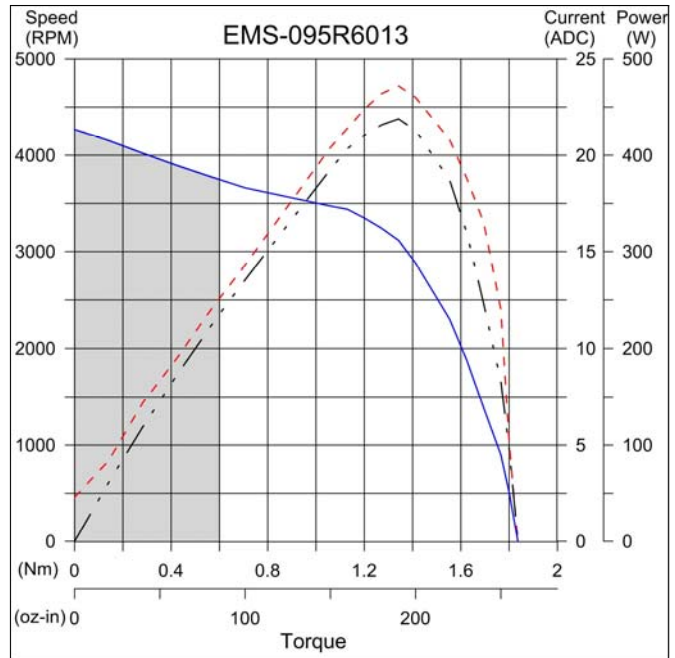
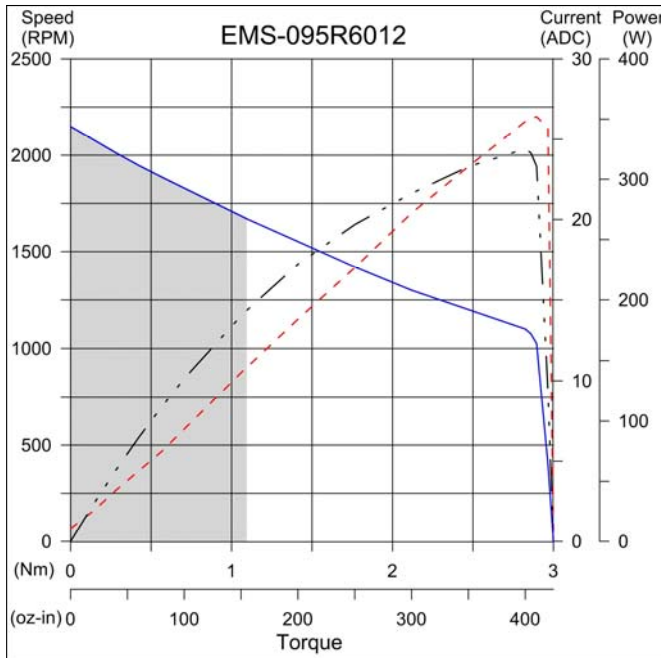

# Brushless DC Motors

## EnduraMax 95s Series Brushless Motor with Integral Drive

### SPECIFICATIONS (9-STACK MODELS)

	EMS-095Q9011	EMS-095Q9015	EMS-095R9012	EMS-095R9013	EMS-095G9012	EMS-095G9013
	Low Speed	High Speed	Low Speed	High Speed	Low Speed	High Speed
DC Input Voltage [VDC $\pm$ 15%]	12		24		48	
Rated Cont. Torque [Nm (oz-in)]	0.98 (140)	0.60 (85)	1.41 (201)	0.81 (115)	1.70 (242)	1.13 (161)
Peak Torque [Nm (oz-in)] <sup>(1)</sup>	1.69 (240)	1.13 (160)	2.97 (420)	1.84 (260)	2.97 (420)	2.97 (420)
Rated Speed [RPM]	1650	2800	1450	3000	1500	3000
No-load Speed [RPM]	1900	3100	1750	3150	1850	3150
Rated Cont. Power [W (HP)] <sup>(2)</sup>	170 (0.23)	180 (0.24)	220 (0.30)	260 (0.35)	270 (0.36)	360 (0.48)
DC Input Current [ADC]	19.1	20.0	12.3	13.6	7.2	9.2
Power Derating Above 23°C [W/°C (W/°F)]	1.80 (1.00)	2.26 (1.26)	1.40 (0.78)	3.45 (1.92)	2.81 (1.56)	4.35 (2.42)
Motor Rotor Inertia [E-4 kg-m <sup>2</sup> (oz-in-sec <sup>2</sup> )]	1.73 (0.0245)					
Weight [kg (lb)]	2.55 (5.62)					
Available Control Modes	Open-loop speed control "OLV" mode (standard), current mode, and velocity mode					
Amplifier Type	PWM (20 kHz) 4-quadrant control					
Current (Torque) Loop Type	DQ PI, 100 $\mu$ s update time					
Velocity Loop	PID / PDF 200 $\mu$ s update time					
Standard Analog Input	0 to +10.0 VDC, 10k $\Omega$ , 12-bit resolution					
Standard Digital I/O	<ul style="list-style-type: none"> <li>Reverse direction input: +3 to +60 V (high); 0 to +0.5 V (low) at 3 mA nominal draw, sourcing</li> <li>Speed/status output: open collector, +60 V max., 100 mA max. sink</li> </ul>					
Speed / Status Output	<ul style="list-style-type: none"> <li>Speed monitor: 9 pulses per motor revolution</li> <li>Drive over-temperature fault: 25% duty-cycle at 10 Hz</li> <li>Bus under-voltage or over-voltage fault: 50% duty-cycle at 10 Hz</li> <li>Stall or short-circuit fault: 75% duty cycle at 10 Hz</li> <li>Other fault: 100% duty cycle</li> <li>Disabled: 0 V (nominal) output</li> <li>Externally visible status LED notifies user of motor condition</li> </ul>					
Standard Protection Features	<ul style="list-style-type: none"> <li>I<sup>2</sup>T current foldback</li> <li>Over-voltage detect<sup>(3)</sup></li> <li>Short-circuit protect</li> <li>Reverse polarity protect</li> <li>Load dump protect</li> <li>Drive over-temperature protect</li> <li>IP50 protect level</li> <li>Locked rotor protect (disable after three failed start attempts)</li> </ul>					
Optional Drive Configuration Features (Contact Allied Motion for Details)	<ul style="list-style-type: none"> <li>Customized analog command input voltage ranges</li> <li>Motor winding over-temperature protect</li> <li>Sinking and sourcing inputs</li> <li>Separate motor-enable input</li> <li>IP65 protection level</li> <li>2-wire input</li> <li>PWM speed control</li> <li>Non-isolated, J1939 CAN input<sup>(4)</sup></li> <li>Potentiometer speed control</li> <li>And more...</li> </ul>					
Ambient Storage Temperature	-40 to 125 °C (-40 to 257 °F)					

(1) Maximum of 4 sec.

(2) With motor mounted to aluminum plate 200 x 200 x 10 mm (8 x 8 x 0.375 in) at 23 °C (derate motor power above 23 °C ambient temperature)

(3) The user is responsible for checking the details of their power source to determine its ability to accept regenerated energy if produced by the user's system

(4) The user is responsible for providing CAN isolation if required by the user's system. Available with custom or Allied Motion's standard J1939 protocol

### PERFORMANCE (9-STACK MODELS)

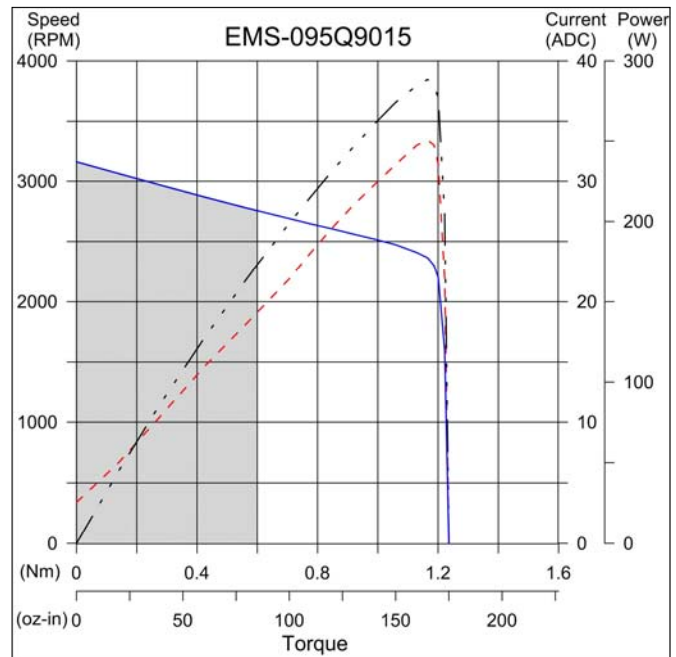
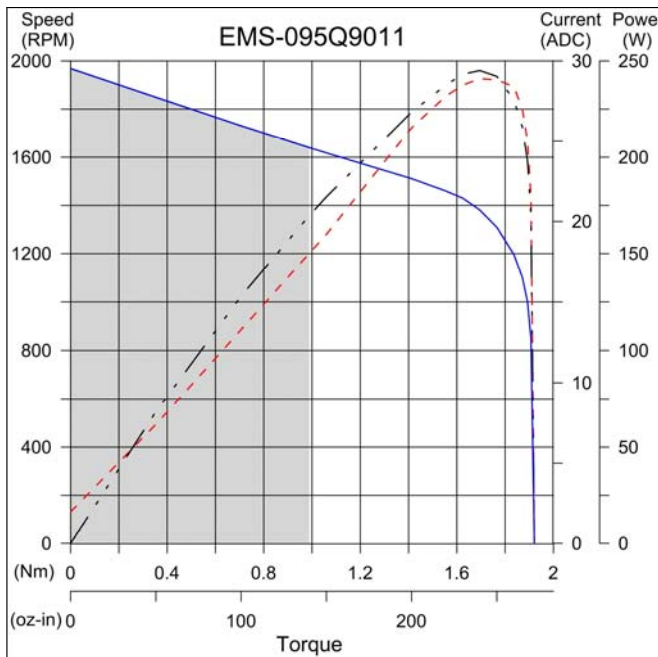

# Brushless DC Motors

## EnduraMax 95s Series Brushless Motor with Integral Drive

### PERFORMANCE (9-STACK MODELS)

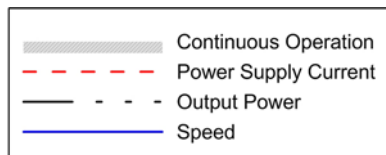
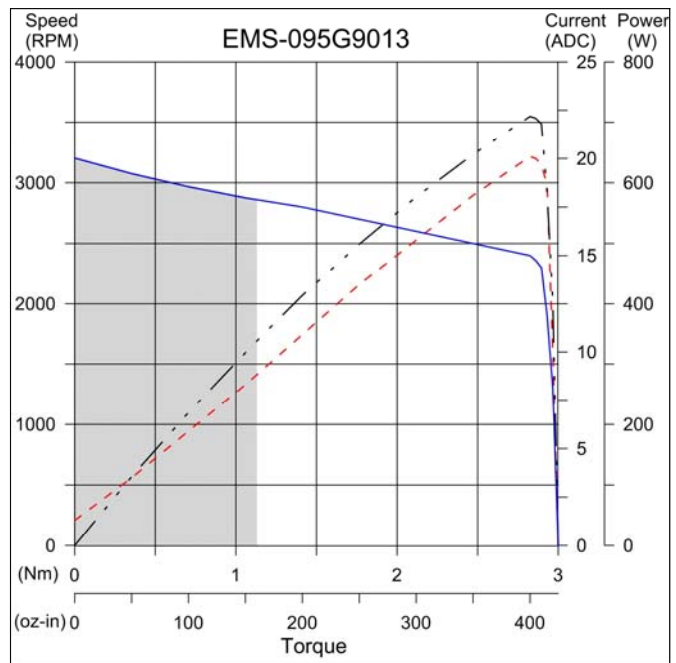
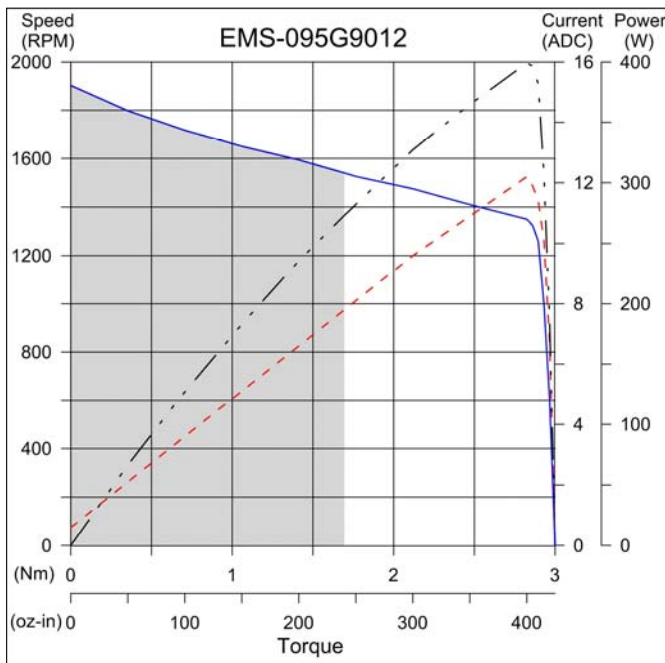
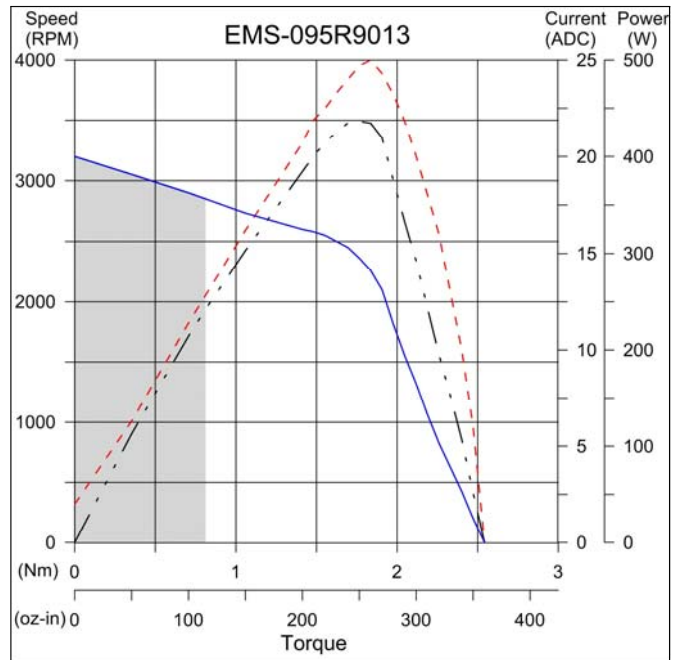
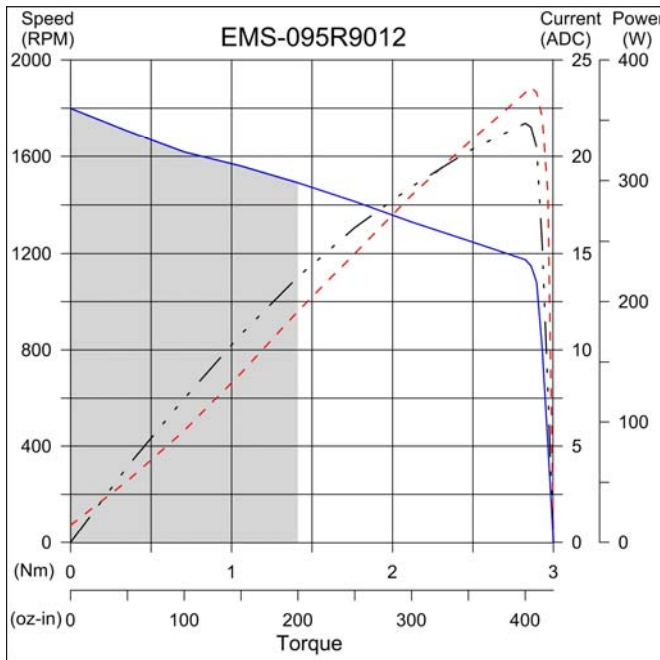

# Brushless DC Motors

## EnduraMax 95s Series Brushless Motor with Integral Drive

### DIMENSIONS

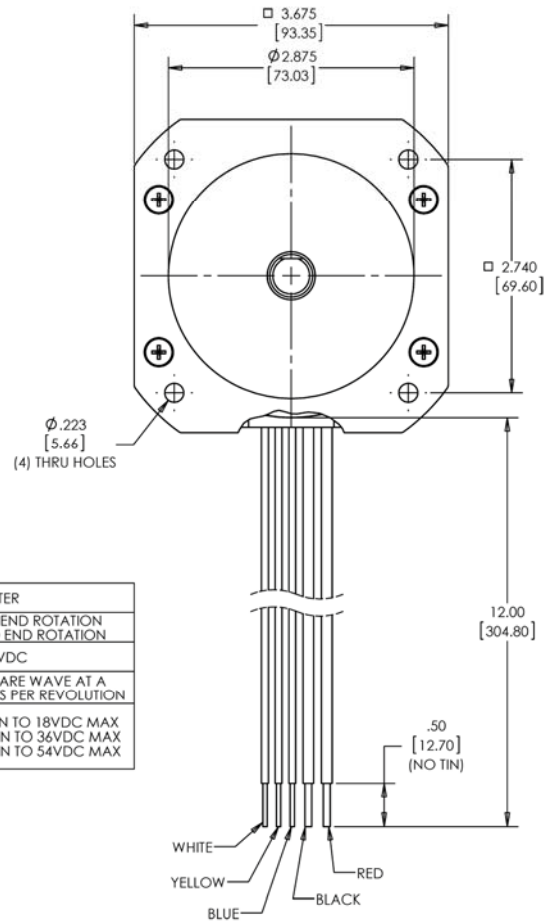
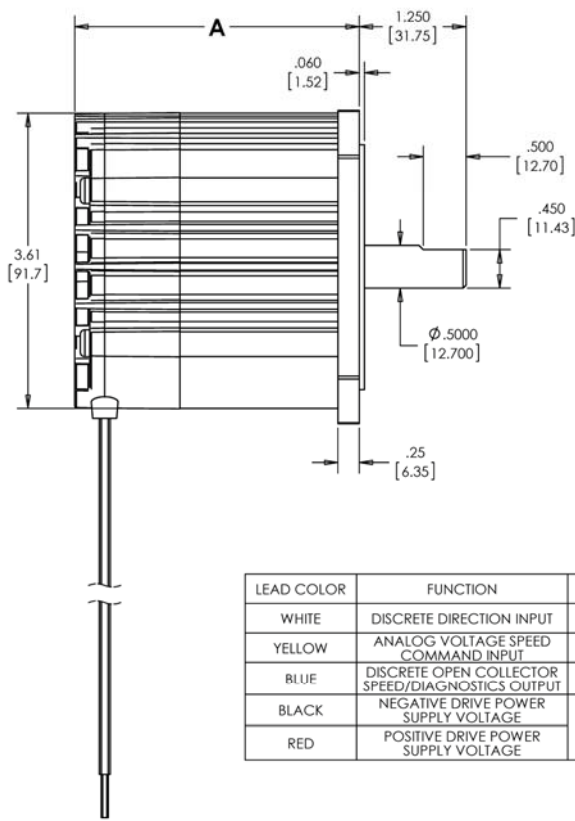

LEAD COLOR	FUNCTION	PARAMETER
WHITE	DISCRETE DIRECTION INPUT	>0.5 VDC= CW LEAD END ROTATION <0.5 VDC=CCW LEAD END ROTATION
YELLOW	ANALOG VOLTAGE SPEED COMMAND INPUT	0 TO 10.0 VDC
BLUE	DISCRETE OPEN COLLECTOR SPEED/DIAGNOSTICS OUTPUT	50% DUTY CYCLE SQUARE WAVE AT A FREQUENCY OF 9 CYCLES PER REVOLUTION
BLACK	NEGATIVE DRIVE POWER SUPPLY VOLTAGE	12VDC NOM: 9VDC MIN TO 18VDC MAX 24VDC NOM: 18VDC MIN TO 36VDC MAX
RED	POSITIVE DRIVE POWER SUPPLY VOLTAGE	48VDC NOM: 36VDC MIN TO 54VDC MAX

MODEL	2-STACK	6-STACK	9-STACK
Length A [in (mm)]	3.330 (85)	4.080 (104)	4.830 (123)



# Brushless DC Motors

## EnduraMax 95s Series Brushless Motor with Integral Drive

### STANDARD I/O CIRCUIT DRAWINGS

#### SPEED CONTROL ANALOG INPUT

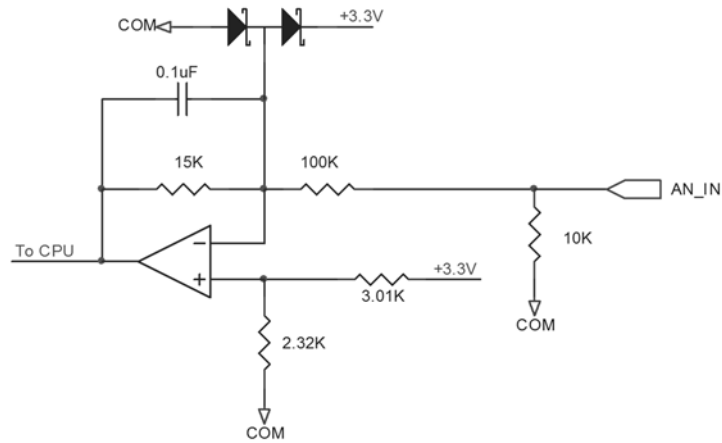

#### SPEED/STATUS SINKING OUTPUT

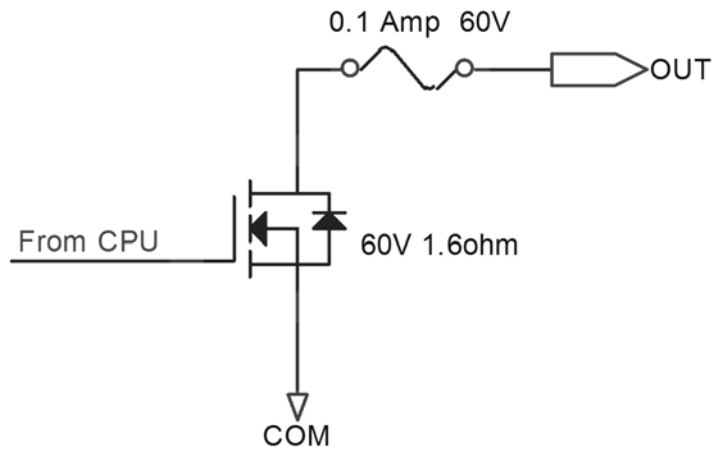

#### REVERSE DIRECTION SOURCING INPUT

