

# NB-15 WITH 1.875" & 3" GEAR TRAINS

Brushless DC Gearmotors

# AN-1532

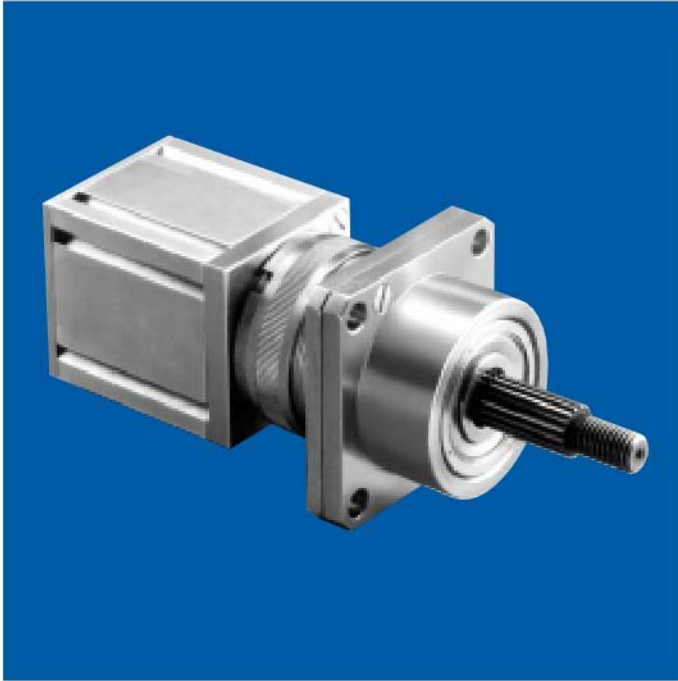

**torque rating:**

1.875" flange:	3.00" flange:
100 lb. in.,	550 lb. in.,
continuous duty	continuous duty

**weight:** Motor/gear/electronic connector module

1.875" flange:	3.00" flange:
1.4 to 2.0 lbs.	5.6 to 6.3 lbs.
depending on ratio	depending on ratio

**gears:** Planetary gearing system. All gears are heat treated and ride on ball or roller bearings for greatest efficiency and long life

**shaft:** Carbon steel shaft per QQ-S-624 with 18-tooth spline serrations per ANS B92.1-1970 heat treated to RC 45-48 (1.875" flange) and RC 29-33 (3.00" flange)

**backlash:** Varies with reduction but average unit will have less than 3°

**gear inertia:**  $1.4 \times 10^{-5}$  oz. in. sec.<sup>2</sup> @ input max

**bearings:** Output shaft uses double-shielded, life-lubricated ball bearings for -55°C to +85°C operation. Special lubricants available for temperature extremes

**cables/leads:** 8 lead wires (MIL-W-16878/4), 18" minimum

**mounting flange:** Cold drawn steel

**gear train housing:** Stress-proof steel

**marking:** Per MIL-STD-130

**options available:**

- RFI filters to meet MIL-I-6181, MIL-I-26600 or MIL-STD-461

**Dimensions**

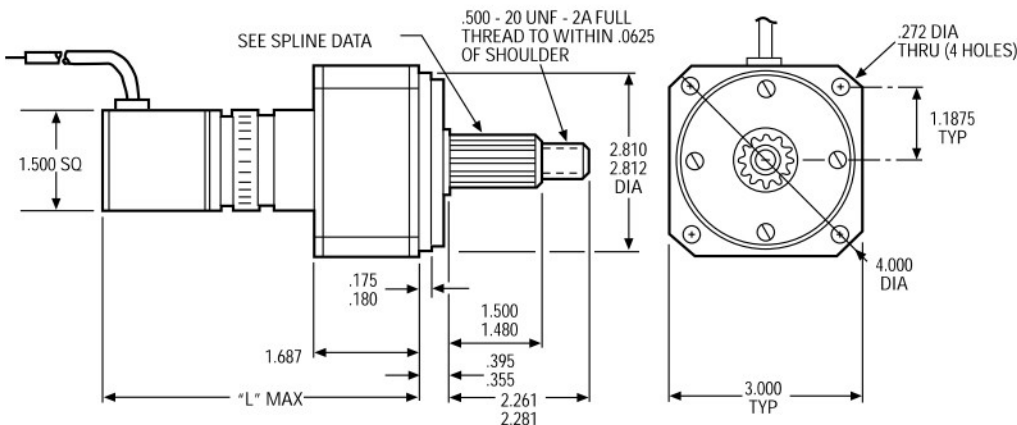
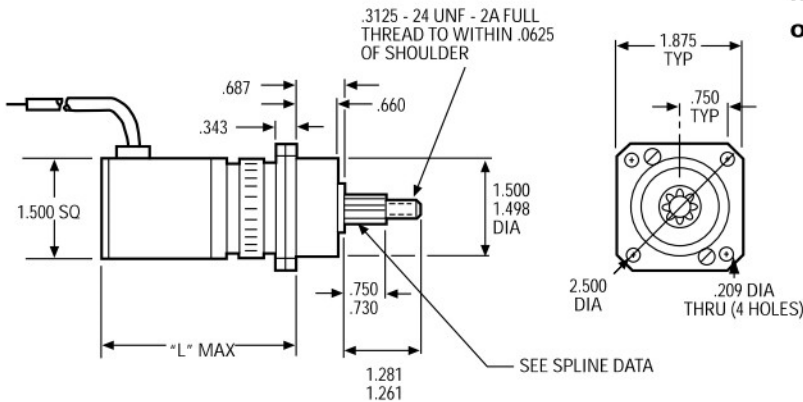

# AN-1532

## Spline Data

### 1.875" Flange

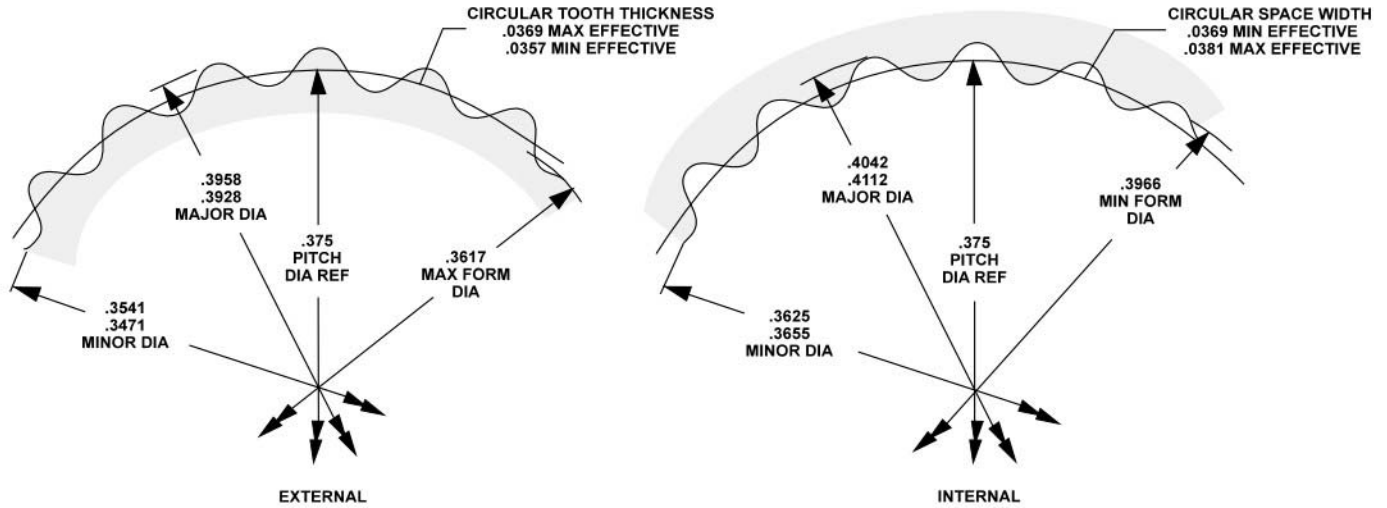

INVOLUTE SPLINE PER ANS B92.1-1970 (GLOBE SPEC 3S95)  
 18 TEETH  
 48/96 PITCH  
 45° PRESSURE ANGLE  
 EXTERNAL SPLINE — MIN DIMENSION OVER TWO .040" DIA PINS .4398" REF  
 INTERNAL SPLINE — MAX DIMENSION BETWEEN TWO .040" DIA PINS .3174" REF  
 NOTE: FOR PROTOTYPES, GLOBE MOTORS WILL BROACH THRU-HOLES FOR NON-HARDENED MATING PARTS WITH AN I.D. OF .3575/.3585" AS A STARTING DIAMETER

### 3.00" Flange

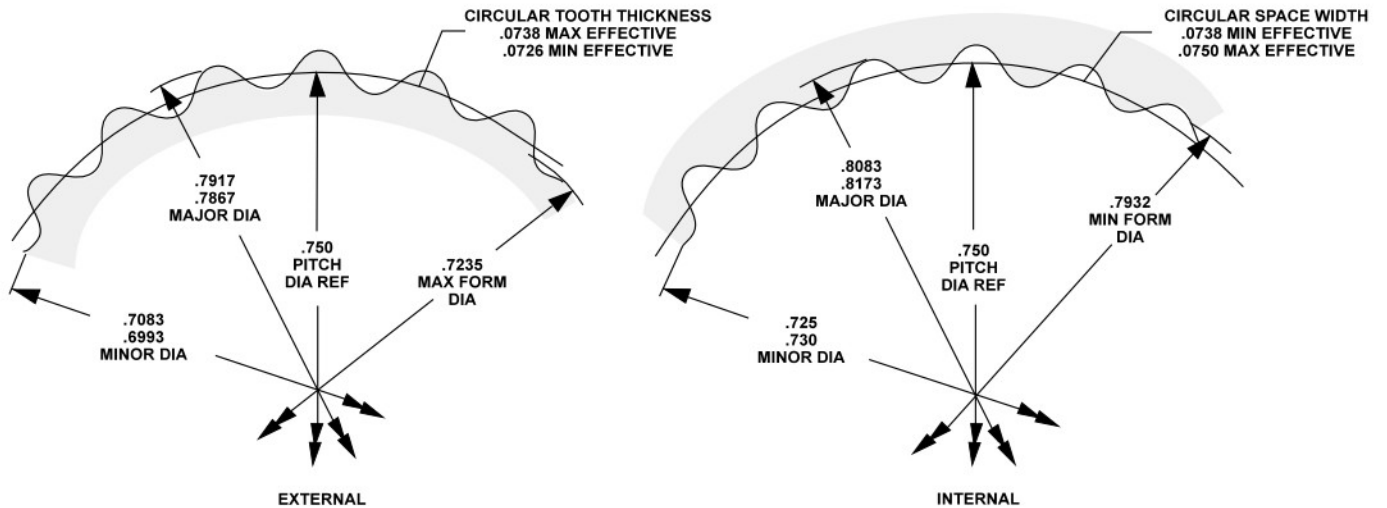

INVOLUTE SPLINE PER ANS B92.1-1970 (GLOBE SPEC 3S96)  
 18 TEETH  
 24/48 PITCH  
 45° PRESSURE ANGLE  
 EXTERNAL SPLINE — MIN DIMENSION OVER TWO .080" DIA PINS .8819" REF  
 INTERNAL SPLINE — MAX DIMENSION BETWEEN TWO .080" DIA PINS .6321" REF  
 NOTE: FOR PROTOTYPES, GLOBE MOTORS WILL BROACH THRU-HOLES FOR NON-HARDENED MATING PARTS WITH AN I.D. OF .7195/.7205" AS A STARTING DIAMETER

# NB-15 WITH 1.875" & 3" GEAR TRAINS

Brushless DC Gearmotors

# AN-1532

## Standard Part Numbers and Data

### 1.875" Flange

SPEED REDUCTION RATIO	TORQUE MULTIPLIER	MAX CONT. RATING (lb. in.)	"L" max (in.)	STANDARD PART NO. PREFIX*
3.81:1	3.5	1.1	3.075	559A180
5.54:1	5.1	1.6		559A181
14.5:1	13.0	4.1	3.260	559A182
21.1:1	19.0	6.0		559A183
30.7:1	27.0	8.6		559A184
55.3:1	47.0	14.6		559A185
80.4:1	68.0	21.0	3.830	559A186
117:1	99.0	31.0		559A187
170:1	144.0	45.0		559A188
211:1	171.0	53.0		559A189
306:1	248.0	77.0	4.010	559A190
445:1	360.0	100.0		559A191
647:1	524.0	100.0		559A192
941:1	762.0	100.0		559A193
1,166:1	896.0	100.0		559A194
1,696:1	1,305	100.0	5.000	559A195
2,466:1	1,900	100.0		559A196
3,584:1	2,760	100.0		559A197
5,211:1	4,000	100.0		559A198

### 3.00" Flange

SPEED REDUCTION RATIO	TORQUE MULTIPLIER	MAX CONT. RATING (lb. in.)	"L" max (in.)	STANDARD PART NO. PREFIX*
306:1	248	77	5.080	559A199
445:1	360	122		559A200
647:1	524	164		559A201
941:1	762	238		559A202
1,166:1	896	280	5.260	559A203
1,696:1	1,305	407		559A204
2,466:1	1,900	550		559A205
3,584:1	2,760	550		559A206
5,211:1	4,000	550		559A207

Max Cont. Torque: The values in this column are based upon gear train strength  
 Max rated torque of motor selected x torque multiplier ratio must not exceed maximum continuous torque of gearbox  
 Max Intermittent Torque = 2 x Max Cont. Torque  
 Momentary Stall Torque = 5 x Max Cont. Torque  
 Minimum Gearbox Efficiency = Torque Multiplier Ratio divided by Speed Reduction Ratio x 100

### \*When You Order

Each of the basic motor windings (see chart, next page) can be used with any of the gear ratios listed above. To order, state the gear train standard part number prefix, plus a motor winding dash number. EXAMPLE: 559A180-1 is a 3.81:1 NB gearmotor with a "-1" armature winding, 27 volts, 14,000 rpm, 7.00 oz. in. torque, etc.

# AN-1532

## Motor Characteristics

ITEM	ABBREVIATION	UNITS	REFERENCE VALUE
Motor Constant ( $K_T/\sqrt{R}$ )	Km	oz. in./ $\sqrt{W}$	2.45
Electrical Time Constant	Te	msec.	0.59
Mechanical Time Constant	Tm	msec.	9.2
Max Cont Input Power	P	W	119
Temperature Rise†	TPR	°C/W	3.2
Max Winding Temperature		°C	180
Rotor Inertia	Jm	oz. in. sec <sup>2</sup>	0.0004
Number of Poles			4
Winding Connection			3 phase WYE

†Assumes motor is mounted to 8.00" x 8.00" x .25" aluminum heat sink

## Winding Characteristics

VOLTAGE (VDC)	SPEED no load (rpm)	TORQUE		CURRENT			CONSTANTS		MOTOR WINDING DASH NUMBERS*
		max rated (oz. in.)	theoretical stall (oz. in.)	max no load (amps)	max rated load (amps)	max peak (amps)	K <sub>v</sub> (oz. in./amp)	R (ohms)	
27	12,500-15,500	8.5	60.0	.35	3.0	22.0	2.75	1.23	-1
27	9,000-11,000	8.5	48.0	.30	3.0	13.0	3.76	2.13	-2

Note: Alternative windings (voltage, speed) available.

## \*When You Order

Units shown above are standard and may be ordered by part number. Remember to include motor winding dash number, EXAMPLE: 557A103-1

## Lead Wire Designation

LEAD WIRE COLOR CODE			
LEAD	COLORS	AWG	DESCRIPTIONS
+ VDC	RED/WHITE	24	HALL SENSORS
GROUND	BLACK/WHITE	24	
HALL "A"	ORANGE/WHITE	24	
HALL "B"	YELLOW/WHITE	24	
HALL "C"	GREEN/WHITE	24	
PHASE "A"	ORANGE	20	MOTOR LEADS
PHASE "B"	YELLOW	20	
PHASE "C"	GREEN	20	

## Motor Coil Connections

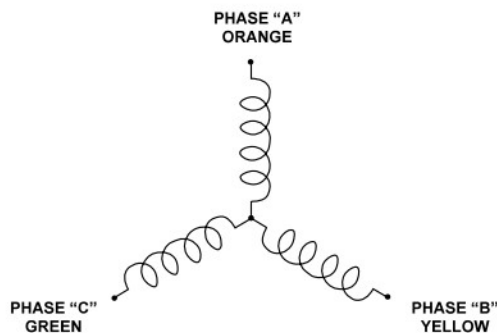

## Commutation and Connection Diagrams

