

TAA Series Standard-Duty Transaxles

3/8 HP, Multi-Reduction, Helical gear, Differentiating

Allied Motion's TAA series of standard-duty transaxles are designed to power medical mobility equipment such as wheelchairs, scooters, patient beds, and similar applications. The TAA is additionally employed in many material handling applications.

The proven TAA transaxles are available with either of two PMDC motor sizes and a choice of motor winding voltage from 12 up to 240 VDC. The TAA series are capable of up to 3/8 HP continuous output power.

In addition to medical mobility service, the TAA series are a good choice for many utility vehicle applications such as material handling carts, floor care, AGVs, and light construction or transport/hauling vehicles.

Features & Benefits

- Rated for vehicle weights up to 1200 lb (544 kg)
- Hardened steel and powder metal gears for durability and long life
- Die cast aluminum gearbox minimizes weight and adds strength
- Class A (105 °C) winding insulation
- Cartridge style brushes for easy maintenance
- Differential gearing for smooth, jitter-free turning
- Synthetic grease lubrication for long service life
- Ball and needle bearing construction for durability
- 4-pole motor for excellent reserve ramp-climbing power
- 3/4-inch (19mm) dia. output shafts

- Modular design of motor, gearbox, and brake eases repair/replacement
- Electromechanical holding brake, rated at 50 lb-in (5.7 Nm), with override and controller feedback
- 20:1 gear ratio with low diametral pitch for increased gear strength

Options

- High temperature Class H (180 °C) winding insulation
- Weather-proof (IP65) design
- Custom leads and/or connectors
- Grease fitting to lubricate output shaft needle bearings
- Non-brake version
- Custom output shaft configurations
- Small transaxle for narrow wheelbase applications



- Specifically designed for medical mobility and utility vehicle applications with vehicle weight up to 1200 lb (544 kg)
- 24 VDC PMDC motor; optional winding voltages from 12 up to 240 VDC
- Up to 3/8 HP continuous output power

SPECIFICATIONS

Model	Voltage (VDC)	Gear Ratio	Weight lb (kg)	Rated Torque lb-in (Nm)	Rated Speed RPM	No-load Speed RPM	Current			Rated Power HP (W)
							Pk A	Rated A	NL A	
GTA-51360096	24	20:1	20 (9)	100 (11.3)	156	172 - 198	94	12	.5	0.25 (187)
GTA-51360095	24	20:1	20 (9)	125 (14)	155	162 - 186	137	18	4.5	0.30 (224)

Transaxles

TAA Series Standard-Duty Transaxles

GTA-51360096

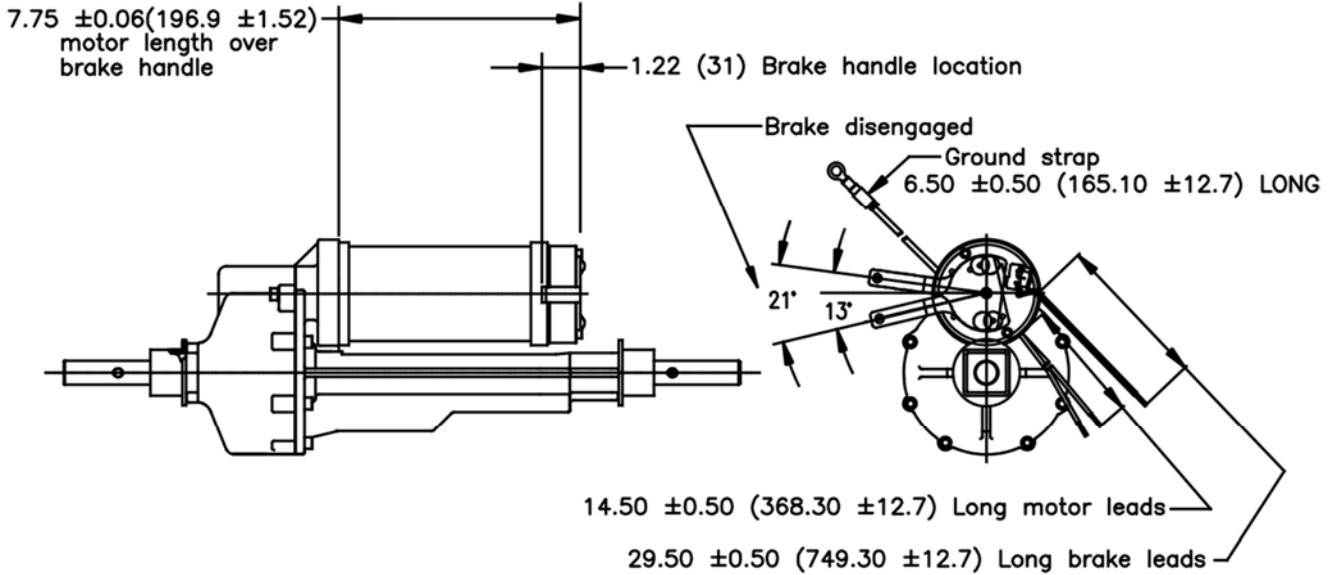

(All other dimensions per GTA-51360095)

Dimensions shown are in (mm)



GTA-51360095

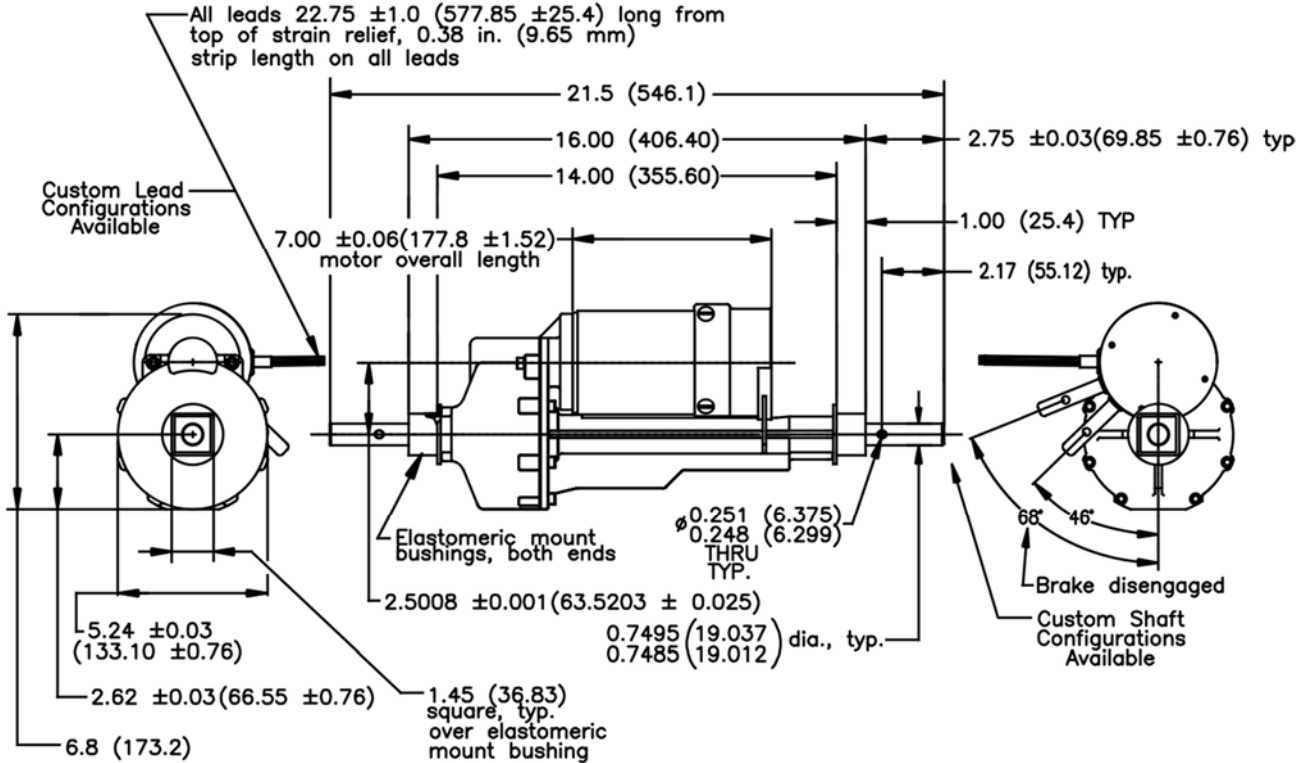

Dimensions shown are in (mm)



TAA Series Standard-Duty Transaxles

PERFORMANCE

GTA-51360096

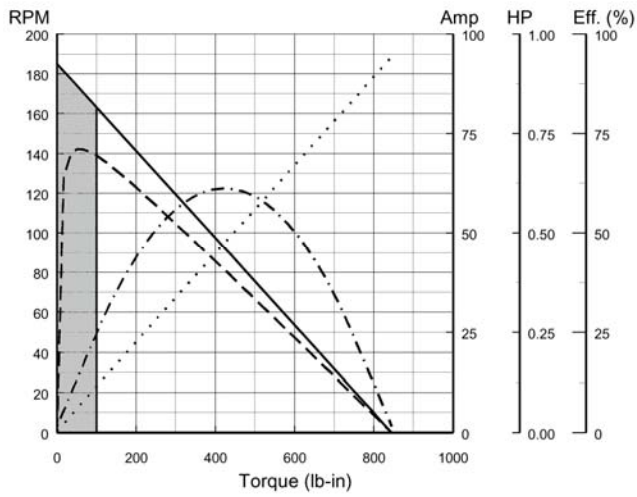

GTA-51360095

