



HMP04 Servo Motors



The HeiMotion Premium series of brushless AC servo motors are engineered to meet the most demanding application requirements. Five frame sizes are offered covering a wide range of torque levels and speeds. Use of our proven compressed winding technology enables the realization of a more compact motor with lower production costs compared to other motors on the market.

The HeiMotion Premium motors are available in five standard frame sizes:

- 40 mm - HMP04
- 60 mm - HMP06
- 80 mm - HMP08
- 100 mm - HMP10
- 130 mm - HMP13

Key HeiMotion Premium features:

- Outstanding servo performance
- Highly configurable to fit virtually any application
- High efficiency
- Optimized moment of inertia
- Long service life
- Compact design
- High power density
- High overload capacity
- Low cogging torque
- Energy efficient

HeiMotion Premium motors basic performance values

Type	Model	U_{Bus}	I_0	I_n	M_0	M_n	M_{max}	n_n	J	$P_n (S1)$
		[V]	[A]	[A]	[Nm]	[Nm]	[Nm]	[rpm]	[kg-cm ²]	[W]
HMP04	HMP04-002	48	1.8	1.7	0.18	0.16	0.6	3,000	3.00E-02	50
		48	3.4	3.0	0.18	0.14	0.7	6,000	3.00E-02	85
		320	0.8	0.7	0.18	0.12	0.7	9,000	3.00E-02	110
	HMP04-004	48	3.5	3.3	0.35	0.32	1.3	3,000	5.40E-02	100
		48	6.3	5.7	0.35	0.28	1.3	6,000	5.40E-02	175
		320	1.6	1.2	0.35	0.21	1.4	9,000	5.40E-02	200
HMP06	HMP06-007	320	0.9	0.8	0.7	0.6	2.8	3,000	2.20E-01	200
		320	1.6	1.3	0.7	0.5	2.8	6,000	2.20E-01	325
	HMP06-015	320	1.8	1.5	1.5	1.2	6.0	3,000	4.13E-01	400
		320	3.3	2.2	1.5	0.9	6.0	6,000	4.13E-01	550
HMP08	HMP08-028	320	3.1	2.6	2.8	2.4	11.2	3,000	1.40E00	750
		320	5.6	3.7	2.8	1.7	11.2	5,500	1.40E00	1,000
		560	1.8	1.6	2.8	2.3	11.2	3,000	1.40E00	750
		560	3.3	2.2	2.8	1.7	11.2	5,500	1.40E00	1,000
	HMP08-035	320	3.9	3.7	3.5	3.2	14.0	3,000	1.93E00	1,000
		320	7.1	4.8	3.5	2.1	14.0	5,500	1.93E00	1,200
		560	2.2	2.1	3.5	3.2	14.0	3,000	1.93E00	1,000
		560	3.9	2.8	3.5	2.1	14.0	5,500	1.93E00	1,200
HMP10	HMP10-056	560	3.4	3.0	5.6	4.8	22.4	3,000	4.84E00	1,500
		560	5.4	3.7	5.6	3.4	22.4	5,000	4.84E00	1,800
	HMP10-075	560	4.6	4.1	7.5	6.4	30.0	3,000	6.41E00	2,000
		560	7.5	5.3	7.5	4.8	30.0	5,000	6.41E00	2,500
HMP13	HMP13-055	320	4.8	4.1	5.5	4.8	22.0	2,000	9.82E00	1,000
		320	8.2	6.0	5.5	4.0	22.0	3,600	9.82E00	1,500
		560	2.7	2.3	5.5	4.8	22.0	2,000	9.82E00	1,000
		560	4.7	3.4	5.5	4.0	22.0	3,600	9.82E00	1,500
	HMP13-091	560	4.4	3.4	9.1	7.2	36.4	2,000	1.40E01	1,500
		560	7.7	5.0	9.1	6.0	36.4	3,600	1.40E01	2,250
	HMP13-123	560	4.7	4.5	12.3	9.6	49.2	2,000	2.11E01	2,000
		560	10.3	6.7	12.3	8.0	49.2	3,600	2.11E01	3,000
	HMP13-185	560	8.4	6.5	18.5	14.4	74.0	2,000	3.38E01	3,000
		560	14.8	8.0	18.5	10.0	74.0	3,600	3.38E01	3,750

Ambient conditions & technical characteristics

Motor type	Permanent magnet three-phase synchronous servo motor	
Ambient operating temperature	- 10 °C to + 40 °C	
Ambient storage temperature	- 20 °C to + 70 °C	
Humidity	< 90 % relative humidity (without condensation)	
Insulation class	F (155 °C) $\Delta T = 115 K$	
Protection class	IP65 (standard version), except drive end, protection class is IP21 without shaft oil seal	
Cooling	Natural convective	
Bearing life	20,000 h under rated operation conditions (M_n)	
Temperature sensor	KTY84-130	
Voltage slew rate dU/dt	8 kV / μs	
Maximum altitude	4,000 meters above sealevel; derate 1 % per 100 meters above 1,000 meters).	
Concentricity, coaxial and axial run-out	N (normal) per DIN 42955	
Vibration	Stage N in accordance with ISO 2373	
Cogging torque factor t_c	HMP04 HMP06 HMP08 HMP10 HMP13	< 2.8 % based on the stall torque (M_0) < 2.5 % based on the stall torque (M_0) < 2.0 % based on the stall torque (M_0) < 1.7 % based on the stall torque (M_0) < 1.5 % based on the stall torque (M_0)
Coating	Black top coat, RAL 9005	
Magnet material	Neodymium-Iron-Boron (NdFeB)	
Shaft end	Cylindrical shaft end with / without keyway	
Balancing quality	Q 2.5	
Encoder systems	Resolver, SinCos® SEK/SEL 37, SKS/SKM 36, EKS/EKM 36, SRS/SRM 50, EFS/EFM 50, CKS 36, HEM/HES	
Approvals	CE,  - certification	

Unit abbreviations & definitions

Abbr.	Unit	Explanation
f_n	[Hz]	Nominal frequency
I_0	[A _{rms}]	Stall current per phase (Motor current at stall torque M_0)
I_n	[A _{rms}]	Rated current (Nominal current per phase)
I_{max}	[A _{rms}]	Peak current (Maximum permissible current per phase)
J	[kgcm ²]	Moment of inertia rotor (motor without brake)
k_e	[V _{rms} / krpm]	Voltage constant (Induced voltage between two phases at 1,000 rpm) rms (root mean square value)
k_t	[Nm / A _{rms}]	Theoretical torque constant (rms), without losses at 20 °C
L_{p-p}	[mH]	Winding inductance (phase-to-phase) at rated current I_n
m	[kg]	Weight (motor without brake)
M_0	[Nm]	Stall torque (Stall torque at S1)
M_n	[Nm]	Rated torque (Continuous torque at S1)
M_{max}	[Nm]	Peak torque (maximum permissible torque for short periods)
n_n	[rpm]	Rated speed
n_{max}	[rpm]	Maximum speed
P_n	[W]	Rated power (mechanical power at the shaft)
R_{p-p}	[Ω]	Winding resistance (phase-to-phase at winding temperature of 20 °C)
C_t	[%]	Local cogging torque $C_t = \frac{M_{cmax} - M_{cmin}}{M_0} \times 100 \%$
M_{cmax}	[Nm]	Local maximum of the cogging torque
M_{cmin}	[Nm]	Local minimum of the cogging torque
T_{el}	[ms]	Electrical time constant
T_{th}	[min]	Thermal time constant
U_{mot}	[V _{rms}]	Rated motor voltage (phase-to-phase at rated working point), rms
U_{bus}	[V _{DC}]	DC bus voltage

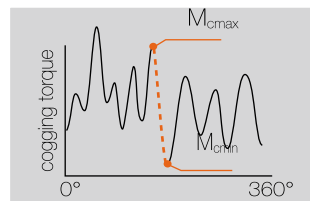

Shaft loading forces

Life span of the motors is at least 20,000 hours if operated under nominal conditions. The table below shows admissible radial forces for the bearing load. Point of force application is in the middle of the shaft (see drawing).

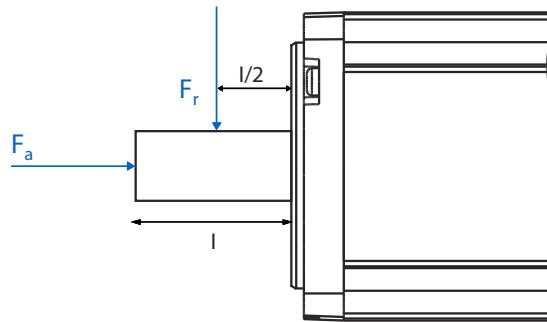

Maximum radial force F_r , [N]

	1,000 [rpm]	2,000 [rpm]	3,000 [rpm]	4,000 [rpm]	5,000 [rpm]	6,000 [rpm]	7,000 [rpm]	8,000 [rpm]	9,000 [rpm]
HMP04-002	215	170	150	135	125	120	115	110	105
HMP04-004	235	185	160	150	135	130	125	120	115
HMP06-007	350	290	250	230	210	200	190	180	-
HMP06-015	390	310	270	250	230	220	205	195	-
HMP08-028	500	400	350	320	300	270	260	-	-
HMP08-035	520	410	360	320	300	280	265	-	-
HMP10-056	940	740	650	590	550	515	-	-	-
HMP10-075	970	770	680	615	570	540	-	-	-
HMP13-055	820	650	570	510	480	-	-	-	-
HMP13-091	860	680	590	540	500	-	-	-	-
HMP13-123	1,100	900	790	710	660	-	-	-	-
HMP13-185	1,200	960	840	760	700	-	-	-	-

Maximum axial force: $F_a = 0.2 \times F_r$

At stall, a one-time axial force of 40 % of the radial force may be applied during motor mounting. Maximum allowed axial and radial forces must not occur together at the same time.

Configuration key

HMP08-028-320-30-B0H2MW23W	
<p>Frame/flange size</p> <p>40 mm → 04 60 mm → 06 80 mm → 08 100 mm → 10 130 mm → 13</p> <p>Stall torque</p> <p>0.2 Nm → 002 0.4 Nm → 004 0.7 Nm → 007 1.5 Nm → 015 2.8 Nm → 028 3.5 Nm → 035 5.6 Nm → 056 7.5 Nm → 075 5.5 Nm → 055 9.1 Nm → 091 12.3 Nm → 123 18.5 Nm → 185</p> <p>DC bus voltage</p> <p>24 V → 024 48 V → 048 320 V → 320 560 V → 560</p> <p>Rated speed</p> <p>2,000 rpm → 20 3,000 rpm → 30 3,600 rpm → 36 5,000 rpm → 50 5,500 rpm → 55 6,000 rpm → 60 9,000 rpm → 90</p>	<p>Options</p> <p>Without brake 0XXXXXXXXX Brake BXXXXXXXXX Without feather key X0XXXXXXXXX Feather key XPXXXXXXXXX Resolver XXR1PXXXXX Resolver safely mounted XXRAPXXXXX SEK 37 XXH1SXXXXX SEL 37 XXH1MXXXXX SKS 36 XXH2SXXXXX SKS 36S safely mounted XXHBSXXXXX SKM 36 XXH2MXXXXX SKM 36S safely mounted XXHBMXXXXX EKS 36 XXD2SXXXXX EKS 36-2 safely mounted XXDBSXXXXX EKM 36 XXD2MXXXXX EKM 36-2 safely mounted XXDBMXXXXX SRS 50 XXH3SXXXXX SRM 50 XXH3MXXXXX EFS 50 XXD3SXXXXX EFM 50 XXD3MXXXXX HES 1 (4.5 V_{ss}) XXM1SXXXXX HES 1 (1.0 V_{ss}) XXM2SXXXXX HEM 1 (1.0 V_{ss} without battery) XXM1MXXXXX HEM 1 (1.0 V_{ss} with battery) XXM2MXXXXX HES 3 XXM1IXXXXX CKS 36 XXI1SXXXXX M23 angled XXXXXW23X Y-Tec XXXXXY17X I-Tec XXXXXI17X Cable outlet 1.5m¹⁾ XXXXXK15X Cable outlet 5 m¹⁾ XXXXXK50X Twintus XXXXXT16X Without radial oil seal XXXXXXXX0 With radial oil seal XXXXXXXXW</p>

1) upon request

Example: HMP08-028-320-30-B0H2MW23W

<p>Frame/flange size: 80 mm</p> <p>Stall torque: 2.8 Nm</p> <p>DC bus voltage: 320 V</p> <p>Rated speed: 3,000 rpm</p>	<p>Options:</p> <p>With brake</p> <p>Without feather key</p> <p>Encoder SKM 36</p> <p>Angled connector M23</p> <p>With radial oil seal</p>
--	---



Specifications

HMP04 - 002

Rated speed [rpm]	n_n	3,000	6,000	9,000
Number of pole pairs	—	2	2	2
Wiring of the motor winding	—	Y	Y	Y
DC bus voltage [V_{DC}]	U_{bus}	48	48	320
Rated voltage motor [V_{rms}]	U_{mot}	27	23	140
Rated power [W]	P_n	50	85	110
Rated torque [Nm]	M_n	0.16	0.14	0.12
Rated current per phase [A_{rms}]	I_n	1.7	3.0	0.7
Stall torque [Nm]	M_0	0.18	0.18	0.18
Stall current per phase [A_{rms}]	I_0	1.8	3.4	0.8
Peak torque [Nm]	M_{max}	0.6	0.7	0.7
Peak current [A_{rms}]	I_{max}	5.7	13.0	3.2
Maximum speed [rpm]	n_{max}	5,210	8,800	10,000
Voltage constant at 1,000 rpm [V_{rms}]	k_e	6.2	3.3	13.5
Torque constant [Nm / A_{rms}]	k_t	0.10	0.05	0.22
Winding resistance (2 phases) at 20 °C [Ω]	R_{ph}	4.9	1.4	25.6
Winding inductance (2 phases) [mH]	L_{ph}	3.0	0.8	14.8
Electrical time constant [ms]	T_{el}	0.6	0.6	0.6
Thermal time constant [min]	T_{th}	15	15	15
Moment of inertia rotor [kg·cm ²]	J	3.00E-02	3.00E-02	3.00E-02
Weight motor [kg]	m	0.5	0.5	0.5

Performance

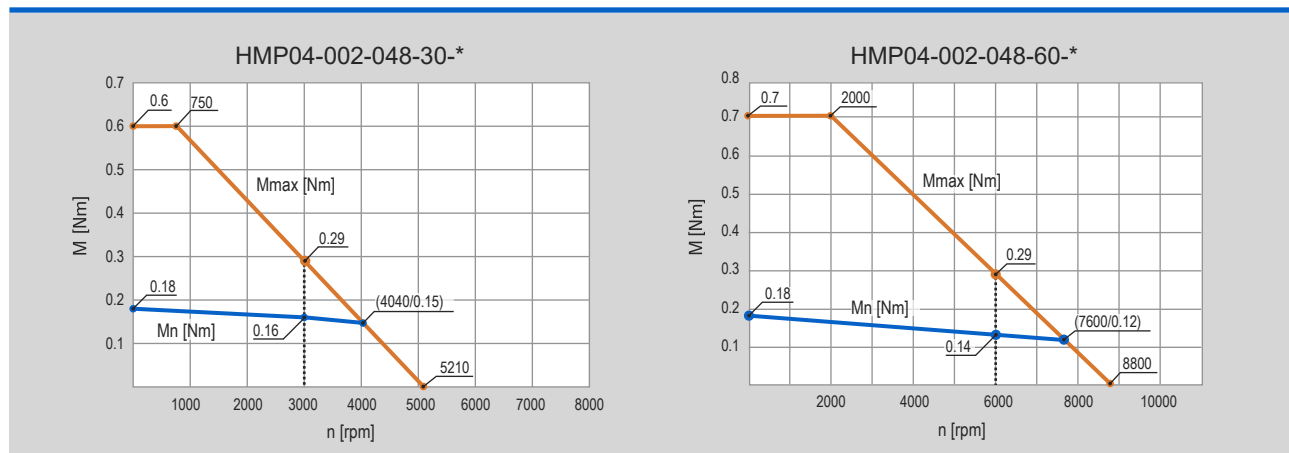

Dimensions

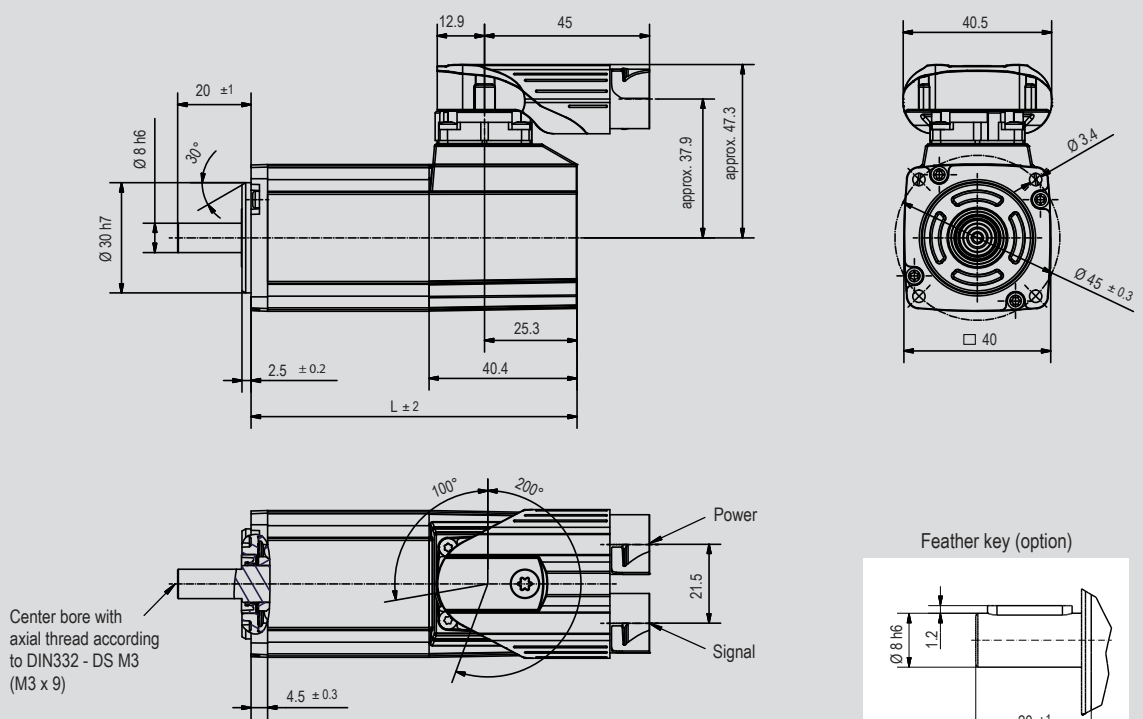

Motor type		L
HMP04-002	without brake	89 mm
HMP04-002	with brake	124 mm

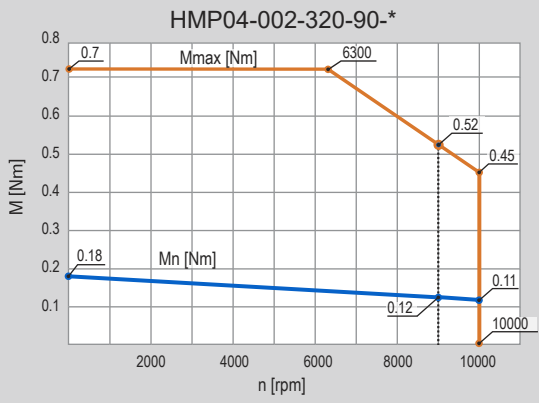



Specifications

HMP04 - 004

Rated speed [rpm]	n_n	3,000	6,000	9,000
Number of pole pairs	—	2	2	2
Wiring of the motor winding	—	Y	Y	Y
DC bus voltage [V_{DC}]	U_{bus}	48	48	320
Rated voltage motor [V_{rms}]	U_{mot}	25	23	132
Rated power [W]	P_n	100	175	200
Rated torque [Nm]	M_n	0.32	0.28	0.21
Rated current per phase [A_{rms}]	I_n	3.3	5.7	1.2
Stall torque [Nm]	M_0	0.35	0.35	0.35
Stall current per phase [A_{rms}]	I_0	3.5	6.3	1.6
Peak torque [Nm]	M_{max}	1.3	1.3	1.4
Peak current [A_{rms}]	I_{max}	12.9	23.5	6.4
Maximum speed [rpm]	n_{max}	5,280	9,540	10,000
Voltage constant at 1,000 rpm [V_{rms}]	k_e	6.1	3.4	13.2
Torque constant [Nm / A_{rms}]	k_t	0.10	0.06	0.22
Winding resistance (2 phases) at 20 °C [Ω]	R_{ph}	1.6	0.4	8.6
Winding inductance (2 phases) [mH]	L_{ph}	1.4	0.4	6.6
Electrical time constant [ms]	T_{el}	0.9	1.1	0.8
Thermal time constant [min]	T_{th}	15	15	15
Moment of inertia rotor [kg-cm ²]	J	5.40E-02	5.40E-02	5.40E-02
Weight motor [kg]	m	0.7	0.7	0.7

Performance

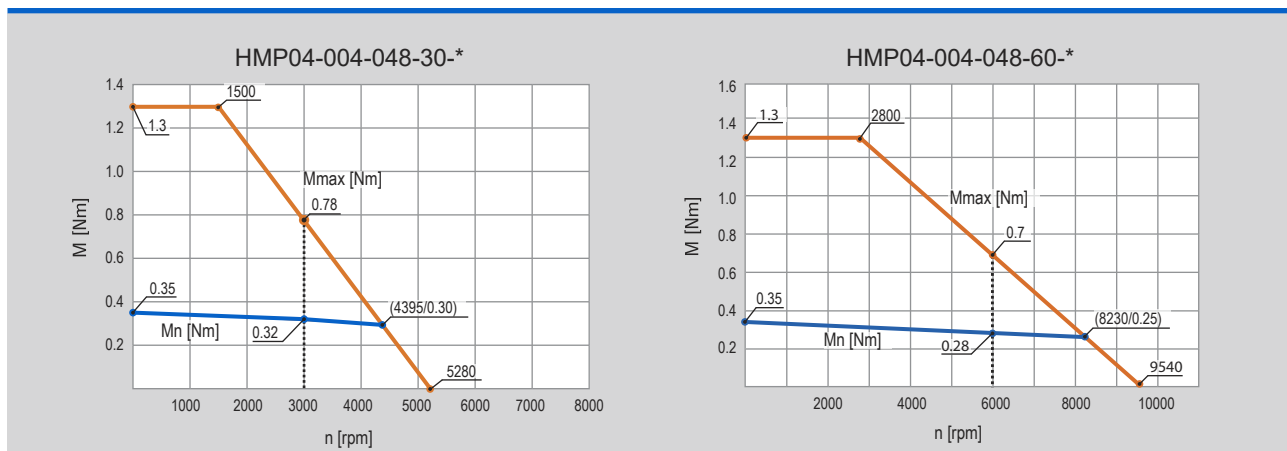

Dimensions

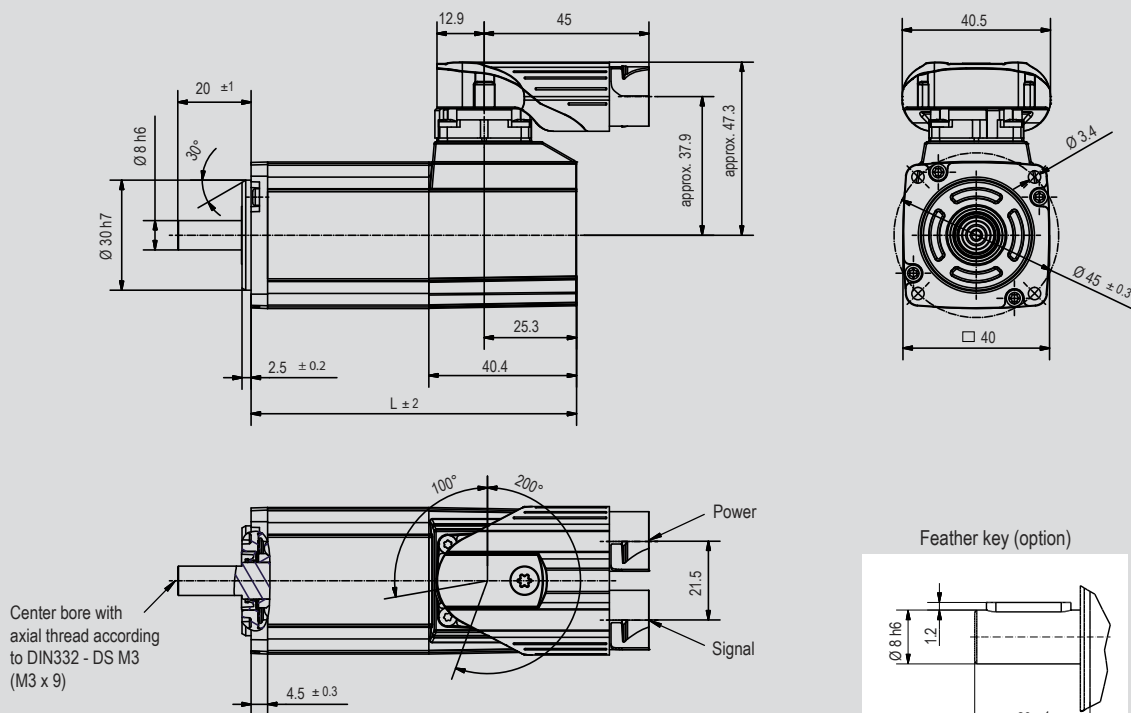

Feather key (option)

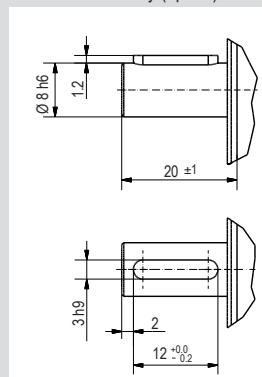

Motor type		L
HMP04-004	without brake	114 mm
HMP04-004	with brake	149 mm

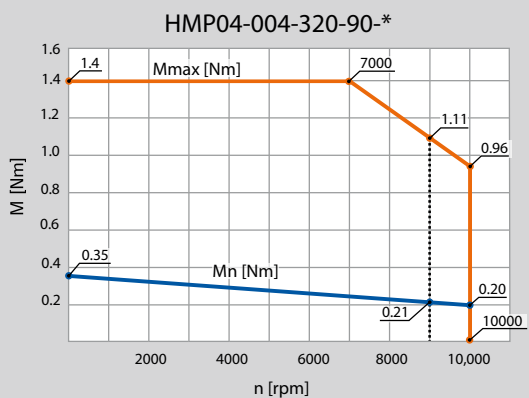

Configuration Options

Connection options

Motor model	Y-Tec*	2 x M23*	I-Tec*	1 x M23*	Twintus	Flying leads
HMP04	X				X	
HMP06	X	X	X	X	X	X
HMP08	X	X	X	X	X	X
HMP10	X	X	X	X	X	X
HMP13	X	X	X	X	X	X
					upon request	upon request

* Standard connectors are rotatable; fixed connector orientation available upon request.

Feedback options

As standard, HeiMotion Premium motors are supplied with a resolver. Optionally, you may choose an encoder in place of the resolver. Available standard encoder types include SinCos encoders with HIPERFACE®-interface or HIPERFACE®-DSL-interface. For motors with these encoders, the motor angular offset is written to the encoder memory.

Motor model	Resolver*	HES/HEM	SEK/ SEL37	SKS/ SKM36*	EKS/ EKM36*	SRS/ SRM50	EFS/ EFM50	CKS36
	Standard	Hall encoder	Absolute encoder	Absolute encoder	Absolute encoder	Absolute encoder	Absolute encoder	Incremental encoder
HMP04	X	X	X					
HMP06	X	X	X	X	X			X
HMP08	X	X	X	X	X	X	X	X
HMP10	X	X	X	X	X	X	X	X
v	X	X	X	X	X	X	X	X

* Safety enhanced version available to allow use of motors in applications up to Cat. 3 / PL d acc. to EN ISO 13849-1 and SIL 2 acc. to EN 62061 / IEC 61508 / EN 61800-5-2

Resolver

Specifications	RE-15
Pole pairs	2
Input frequency	10 kHz
Input voltage	7 V _{rms}
Maximum current input	50 mA
Transformation ratio	0.5 ± 10 %
Phase shift (nominal)	3° ± 3°
Ohmic resistance (at 25 °C)	
Stator winding	70 ± 10 %
Rotor winding	24 ± 10 %
Impedances	
Z _{ro} (no-load impedance rotor)	typ. 86 j 120
Z _{rs} (short-circuit impedance rotor)	typ. 70 j 105
Z _{so} (no-load impedance stator)	typ. 140 j 273
Z _{ss} (short-circuit impedance stator)	typ. 122 j 244
Maximum residual voltage	30 mV
Maximum electrical error	± 10 min.
Weight	77 g
Protection class	IP 20
Insulation class	F
Insulation test housing / winding	500 V _{AC} / 50 Hz / 1 s
Moment of inertia rotor	15 gcm ²



Environmental

Operating environment	IE 32 according to EN 60721-3-3
Operating temperature range	- 55 °C to 155 °C
Vibration according to EN 60068-2-6	100 m/s ² , 10 - 150 Hz
Impact strength	400 m/s ² , 6 ms
Maximum operating speed	20,000 rpm

Dimensions

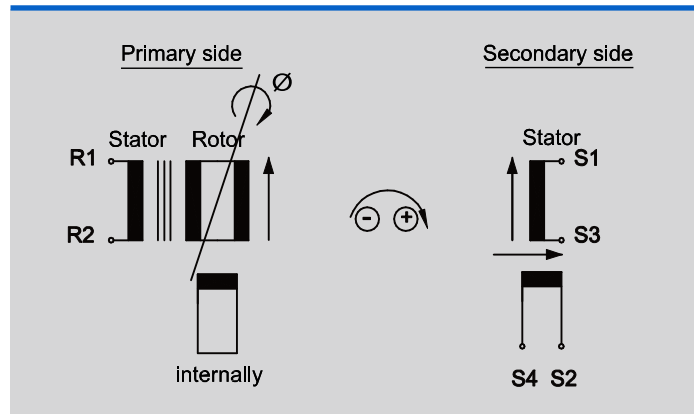

Safety norms

Safety Integrity Level	SIL 2 (61800-5-2 / EN62061 / IEC61508)
Category	3 (EN ISO 13849-1)
Performance Level	PL d (EN ISO 13849-1)



Configuration Options

Magnetic Encoders

HES1-001



Features

- Single-turn encoder with a resolution of 12-bit (interpolated 14-bit)
- SSI interface differential and single-ended
- Differential sin/cos signals with 4.5 V_{p-p}

HES1-002



Features

- Single-turn encoder with a resolution of 12 bit (interpolated 14 bit)
- SSI Interface differential and single-ended
- Differential sin/cos signals with 1.0 V_{p-p}

HEM1-001



Features

- Multi-turn encoder with a resolution of 32 bit (≈ 4.2 billion rotations measurable)
- Single-turn encoder with a resolution of 12 bit (interpolated 14 bit)
- SSI Interface differential and single ended
- Differential sin/cos signals with 1 V_{p-p}
- External battery connector

HEM1-002



Features

- Multi-turn encoder with a resolution of 32 bit (≈ 4.2 billion rotations measurable)
- Single-turn encoder with a resolution of 12 bit (interpolated 14 bit)
- SSI Interface differential and single ended
- Differential sin/cos signals with 1 V_{p-p}
- Battery on board

HES3



Features

- Single-turn encoder with a resolution of 10 bit (interpolated 12 bit)
- Commutation and incremental signals ABZ, differential and single-ended
- Commutation signals for 2/4/6 or 8-pole motors

Specifications

(according to DIN 32878)

	HES1-001	HES1-002	HEM1-001	HEM1-002	HES3
Diameter (nominal)	35 mm	35 mm	35 mm	35 mm	35 mm
Power supply voltage	$5.0 V_{DC} \pm 10\%$	$5.0 V_{DC} \pm 10\%$	$5.0 V_{DC} \pm 10\%$	$5.0 V_{DC} \pm 10\%$	$5.0 V_{DC} \pm 10\%$
Maximum output current	20 mA	20 mA	20 mA	20 mA	150 mA
Maximum resolution single-turn	12-bit 0.088°	12-bit 0.088°	12-bit 0.088°	12-bit 0.088°	10-bit 0.35
Maximum resolution single-turn interpolated	14-bit 0.022°	14-bit 0.022°	14-bit 0.022°	14-bit 0.022°	12-bit 0.088°
Maximum number of turns	-	-	32-bit ≈ 4.2 billion	32-bit ≈ 4.2 billion	-
Backup battery for multi-turn encoder	-	-	external	on board	-
SSI interface	differential & single ended	differential & single ended	differential & single ended	differential & single ended	-
Maximum SSI operating frequency	4 MHz	4 MHz	4 MHz	4 MHz	-
Sin/cos signals	differential	differential	differential	differential	-
Number of sin/cos periods per turn	1	1	1	1	-
Amplitude sin/cos	4.5 Vp-p	1.0 Vp-p	1.0 Vp-p	1.0 Vp-p	-
Incremental signals (ABZ)	-	-	-	-	differential
High-level output voltage ABZ	-	-	-	-	min. 3.8 V
Low-level output voltage ABZ	-	-	-	-	max. 0.7 V
Commutation signals	-	-	-	-	differential
Commutation high-level output voltage (UVW)	-	-	-	-	min. 3.8 V _i
Commutation low-level output voltage (UVW)	-	-	-	-	max. 0.7 V
ESD voltage	2 kV	2 kV	2 kV	2 kV	2 kV
Configuration code segment	XXM1SXXXX	XXM2SXXXX	XXM1MXXXX	XXM2MXXXX	XXM1IXXXXX

Absolute Encoders

SEK / SEL37

(Single- or multi-turn encoder)



Features

- Capacitive sensing encoder
- 16 sin/cos periods per rotation
- Absolute position with a resolution of 512 steps per rotation
- Measuring of 4,096 rotations (multi-turn)
- Programming of the position value
- HIPERFACE interface



SKS / SKM36

(Single- / multi-turn encoder)



Features

- Optical sensing encoder
- 128 sin/cos periods per rotation
- Absolute position with a resolution of 4,096 steps per rotation
- Measuring of 4,096 rotations (multi-turn)
- Programming of the position value
- HIPERFACE interface



SRS / SRM50

(Single- / multi-turn encoder)



Features

- Optical sensing encoder
- 1,024 sin/cos periods per rotation
- Absolute position with a resolution of 32,768 steps per rotation
- Measuring of 4,096 rotations (multi-turn)
- Programming of the position value
- HIPERFACE interface



EKS / EKM36

(Single- / multi-turn encoder)



Features

- Optical sensing encoder
- Absolute position with a resolution of 262,144 steps per rotation
- Measuring of 4,096 rotations (multi-turn)
- Programming of the position value
- HIPERFACE DSL interface



EFS / EFM50

(Single- / multi-turn encoder)



Features

- Optical sensing encoder
- Absolute position with a resolution of 8,388,608 steps per rotation
- Measuring of 4,096 rotations (multi-turn)
- Programming of the position value
- HIPERFACE DSL interface



Specifications

(according to DIN 32878)

	SEK/SEL37	SKS/SKM36	SRS/SRM50	EKS/EKM36	EFS/EFM50
Number of sin/cos periods per rotation	16	128	1,024	-	-
Maximum number of turns	Single SEK 1 Multi SEL 4,096	Single SKS 1 Multi SKM 4,096	Single SRS 1 Multi SRM 4,096	Single EKS 1 Multi EKM 4,096	Single EFS 1 Multi EFM 4,096
Code type for absolute value	binary	binary	binary	binary	binary
Code sequence (1)	ascending	ascending	ascending	ascending	ascending
Measuring step during interpolation of the sin/cos signals (for 12-bit)	20 arc sec	2.5 arc sec	0.3 arc sec	-	-
Maximum sin/cos signals interpretation error, integral non-linearity	± 288 arc sec	± 80 arc sec	± 45 arc sec	± 80 arc sec	± 45 arc sec
Non-linearity of a sin/cos period differential non-linearity	± 144 arc sec (2)	± 40 arc sec (2)	± 7 arc sec (2)	± 40 arc sec (2)	± 7 arc sec
Output frequency	---	0 ... 65 kHz	0 ... 200 kHz	0 ... 75 kHz	0 ... 75 kHz
Resistance to shocks	100 g / 10 ms	100 g / 6 ms	100 g / 10 ms	100 g / 6 ms	100 g / 6 ms
Resistance to vibration	50 g / 10...2,000 Hz	50 g / 10...2,000 Hz	50 g / 10...2,000 Hz	50 g / 10...2,000 Hz	30 g / 10...2,000 Hz
Operating voltage range	7...12 V	7...12 V	7...12 V	7...12 V	7...12 V
Recommended supply voltage	8 V	8 V	8 V	8 V	9 V
Max. operating current without load	< 50 mA	60 mA	80 mA	150 mA	150 mA
Available memory within EEPROM 2048 (3)	1,792 bytes	1,792 bytes	1,792 bytes	8,192 bytes	8,192 bytes
Interface signals					
<ul style="list-style-type: none"> • Process data cable: SIN, REFSIN, COS, REFCOS • Parameter channel: RS 485 	<ul style="list-style-type: none"> • analog, differential • digital 	<ul style="list-style-type: none"> • analog, differential • digital 	<ul style="list-style-type: none"> • analog, differential • digital 	<ul style="list-style-type: none"> • digital 	<ul style="list-style-type: none"> • digital

Safety norms ⁽⁴⁾

		SKS/SKM36S		EKS/EKM36-2	
Safety Integrity Level	-	SIL2 (EN61800-5-2 / EN62061 / IEC 61508)	-	SIL2 (EN61800-5-2 / EN62061 / IEC 61508)	-
Category	-	3 (EN ISO 13849-1)	-	3 (EN ISO 13849-1)	-
Performance Level	-	PL d (EN ISO 13849-1)	-	PL d (EN ISO 13849-1)	-

1) For rotation of the shaft in clockwise direction when facing in the direction of "A"

2) In the nominal position ± 0.1 mm

3) When using the electronic nameplate in operative connection with numerical controls, consider the patent EP 425 912 B 2; use in operative connection with speed controllers is excluded from this rule.

4) Safety norms are only valid for motors with safely mounted encoders.

Incremental Encoder

CKS36



Features

- Optical sensing encoder
- Resolution up to 2,048 pulses per revolution
- Commutation signals for up to 32 pole pairs
- Index pulse 90° or 180°
- Up to 12,000 rpm speed
- Freely programmable

Specifications according to DIN 32878

CKS36

Number of lines per revolution		1 ... 2,048
Commutation signals		1 ... 32 pole pairs
Measurement step		90° / number of lines
Reference signal	Number Position	1 Configurable 90° or 180° electrical, logically linked with A and B
Error limits	"binary" number of lines "non-binary" number of lines	± 0.09° ± 0.13°
Measurement step deviation	"binary" number of lines "non-binary" number of lines	± 0.035° ± 0.07°
Max. output frequency	TTL/RS 422	400 kHz
Resistance	to shocks to vibration	100 g (6 ms) 50 g (10 ... 2,000 Hz)
Operating voltage range		5 V ± 10 %
Maximum operating current without load		60 mA
Interface signals:	Incremental and commutation signals Parameterization interface	according to EIA 422 IIC Bus

Holding Brake

Any HeiMotion Premium motor may be equipped with a permanent-magnet DC holding brake.

Features

- Isolation class: F (155 °C)
- Maximum speed: 10,000 rpm
- Voltage supply: $24 V_{DC} + 6 \% / -10 \%$

Specifications	HMP04		HMP06		HMP08	
	-002	-004	-007	-015	-028	-035
Moment of inertia motor <u>with</u> brake* [kgcm ²]	5.50E-02	7.90E-02	3.19E-01	5.12E-01	1.68E00	2.20E00
Static braking torque [Nm]	0.4	0.4	2.0	2.0	4.5	4.5
Dynamic braking torque [Nm]	0.3	0.3	1.7	1.7	3.8	3.8
Rated input power [W]	8	8	11	11	12	12
Working voltage [V _{DC}]	24	24	24	24	24	24
Input current brake [A]	0.33	0.33	0.46	0.46	0.50	0.50
Energy rating [kJ]	180	180	580	580	580	580
Separating time brake [ms]	10	10	25	25	35	35
Brake delay [ms]	2	2	2	2	2	2
Application delay time [ms]	6	6	10	10	15	15
Weight motor <u>with</u> brake* [kg]	0.65	0.85	1.8	2.35	3.85	4.5

*incl. all attachment parts

Specifications	HMP10		HMP13			
	-056	-075	-055	-091	-123	-185
Moment of inertia motor <u>with</u> brake* [kgcm ²]	5.63E00	7.20E00	1.05E01	1.48E01	2.31E01	3.58E01
Static braking torque [Nm]	9.0	9.0	9.0	9.0	20	20
Dynamic braking torque [Nm]	7.5	7.5	7.5	7.5	15	15
Rated input power [W]	18	18	18	18	24	24
Working voltage [V _{DC}]	24	24	24	24	24	24
Input current brake [A]	0.75	0.75	0.75	0.75	1.00	1.00
Energy rating [kJ]	890	890	890	890	1,290	1,290
Separating time brake [ms]	40	40	40	40	50	50
Brake delay [ms]	2	2	2	2	3	3
Application delay time [ms]	20	20	20	20	40	40
Weight motor <u>with</u> brake* [kg]	7.4	8.75	8.0	9.4	12.2	16.4

*incl. all attachment parts

Note: The motor may not be operated with the brake applied. The brake is designed as a holding brake. An emergency stop of a running motor using the brake is permitted in exceptional cases. The number of emergency stops is limited by the moment of inertia of the entire system.

Configuration Options



Connectors, Y-Tec

Power

Pin	Function
A	U
B	V
C	W
Grounding	PE
1	Therm. Prot. + **
2	Therm. Prot. - **
3	Brake +*
4	Brake -*
5	-

* if applicable

** only with CKS 36

Signal resolver

Pin	Function
1	cos +
2	cos - / refcos
3	sin +
4	sin- / refs sin
5	R1 (ref +)
6	R2 (ref -)
7	-
8	-
9	Therm. Prot. + / Temp +
10	Therm. Prot. - / Temp -
11	-
12	-

Signal Hiperface

Pin	Function
1	cos +
2	cos - / refcos
3	sin +
4	sin- / refs in
5	Data +
6	Data -
7	Us
8	GND
9	Therm. Prot. + / Temp +
10	Therm. Prot. - / Temp -
11	-
12	-

Signal HES/M1

Pin	Function
1	cos +
2	cos - / refcos
3	sin +
4	sin- / refs in
5	V _{CC} / 5 V
6	GND
7	Data +
8	Data -
9	CLK +
10	CLK -
11	Therm. Prot. + / Temp +
12	Therm. Prot. - / Temp -

Motor connector

View mating face

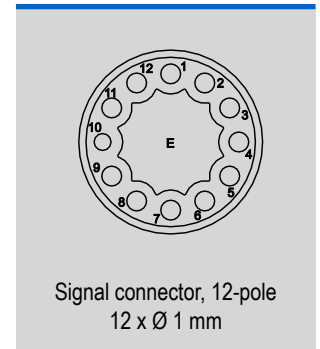
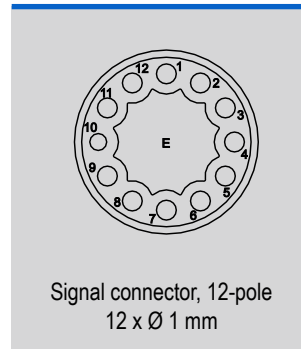
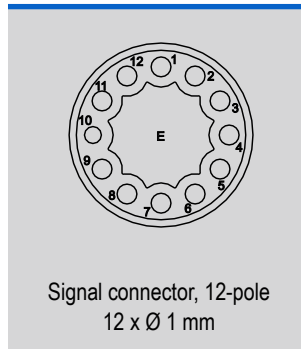
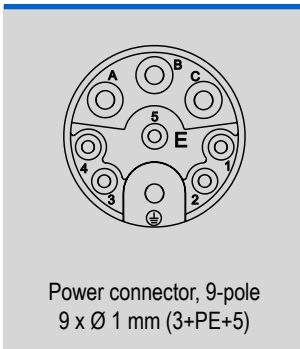

Mating connector

View mating face

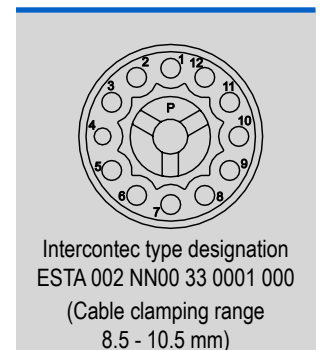
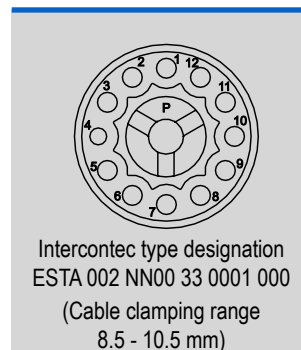
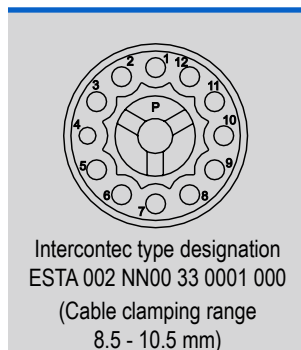
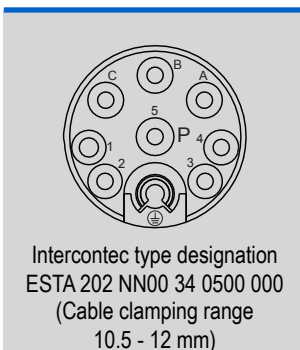

Signal CKS 36

Pin.	Function
1	Z
2	\bar{Z}
3	A
4	\bar{A}
5	B
6	\bar{B}
7	R
8	\bar{R}
9	S
10	\bar{S}
11	T
12	\bar{T}
A	Us
B	GND
C	-

Signal HES3

Pin.	Function
1	Z
2	\bar{Z}
3	A
4	\bar{A}
5	B
6	\bar{B}
7	U
8	\bar{U}
9	V
10	\bar{V}
11	W
12	\bar{W}
A	VCC / 5 V
B	GND
C	-



Mating connectors available with metal fittings only

Motor connector Angled receptacle Y-Tec, rotatable

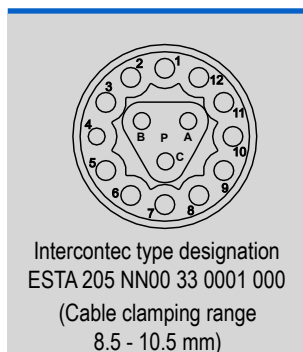
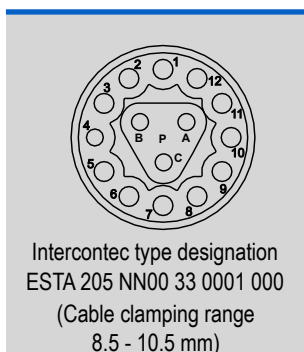
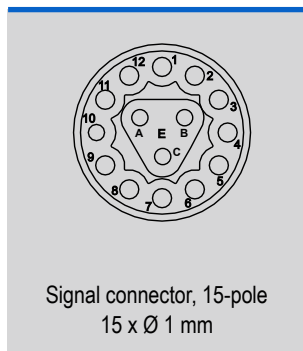
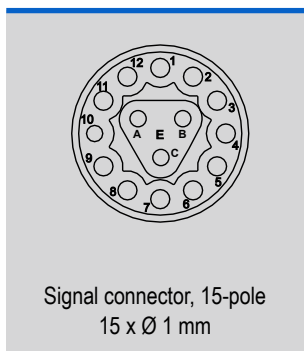
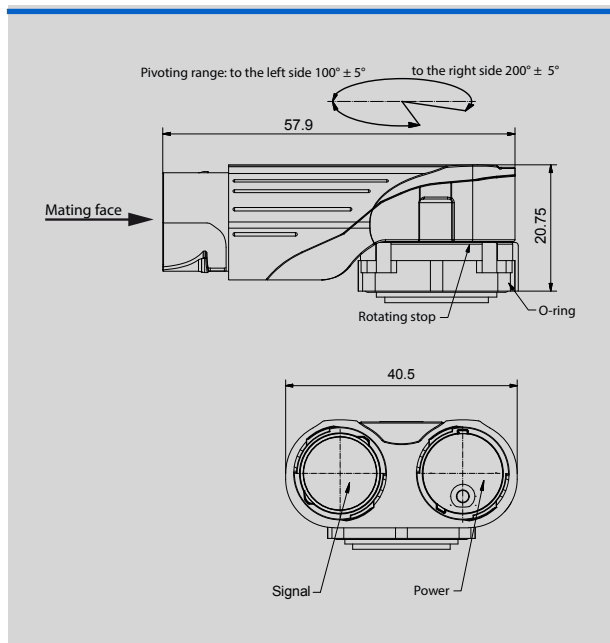

Mating connector

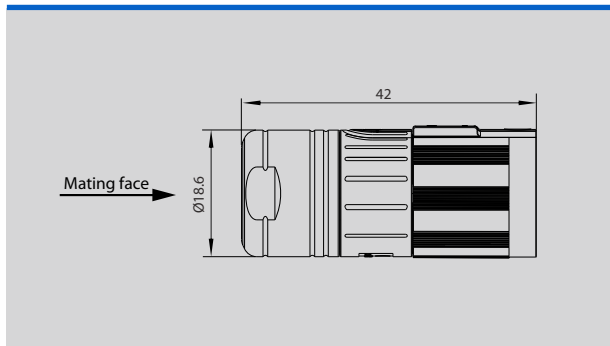

Configuration Options



Connectors, M23

Power

Pin	Function
A	Brake + *
B	Brake - *
C	Therm. Prot. +
D	Therm. Prot. -
1	U
4	V
3	W
Grounding	PE

* if applicable

Signal resolver

Pin	Function
1	cos +
2	cos - / refcos
3	sin +
4	sin - / refs sin
5	-
6	R1 (ref +)
7	R2 (ref -)
8	-
9	-
10	-
11	Therm. Prot. + / Temp +
12	Therm. Prot. - / Temp -

Signal Hiperface

Pin	Function
1	cos +
2	cos - / refcos
3	sin +
4	sin - / refs in
5	-
6	-
7	GND
8	-
9	US
10	Data +
11	Data -
12	-
13	-
14	Therm. Prot. + / Temp +
15	Therm. Prot. - / Temp -
16	-
17	-

Signal HES/M 1

Pin	Function
1	cos +
2	cos - / refcos
3	sin +
4	sin - / refs in
5	V _{CC} / 5 V
6	GND
7	Data +
8	Data -
9	CLK +
10	CLK -
11	Therm. Prot. + / Temp +
12	Therm. Prot. - / Temp -
13	-
14	-
15	-
16	-
17	-

Motor connector

View mating face

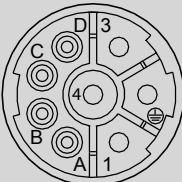

8-pole
4 x Ø 2 mm (3+PE)
+ 4 x Ø 1 mm

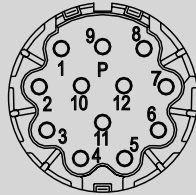

12-pole
12 x Ø 1 mm, 0° coded

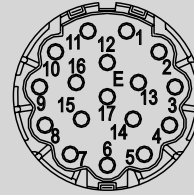

17-pole
17 x Ø 1 mm, 0° coded

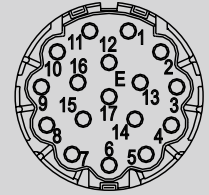

17-pole
17 x Ø 1 mm, 0° coded

Mating connector

View mating face

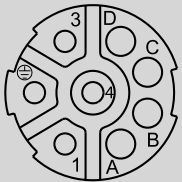

Intercontec type designation
BSTA 078 NN00 42 0100 000
(Cable clamping range
9.5-14.5 mm)

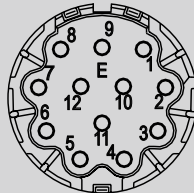

Intercontec type designation
ASTA 013 NN00 41 0100 000
(Cable clamping range
6-10 mm)

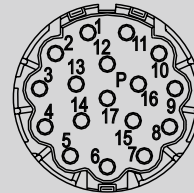

Intercontec type designation
ASTA 014 NN00 41 0100 000
(Cable clamping range
6-10 mm)

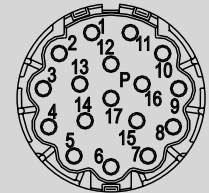

Intercontec type designation
ASTA 014 NN00 41 0100 000
(Cable clamping range
6-10 mm)

Signal CKS 36

Pin	Function
1	Z
2	\bar{Z}
3	A
4	\bar{A}
5	B
6	\bar{B}
7	R
8	\bar{R}
9	S
10	\bar{S}
11	T
12	\bar{T}
13	Us
14	GND
15	Therm. Prot. +
16	Therm. Prot. -
17	-

Signal HES3

Pin	Function
1	Z
2	\bar{Z}
3	A
4	\bar{A}
5	B
6	\bar{B}
7	U
8	\bar{U}
9	V
10	\bar{V}
11	W
12	\bar{W}
13	V _{CC} / 5 V
14	GND
15	Therm. Prot. +
16	Therm. Prot. -
17	-



Motor connector

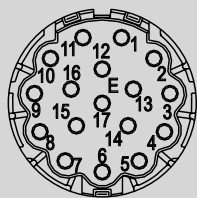
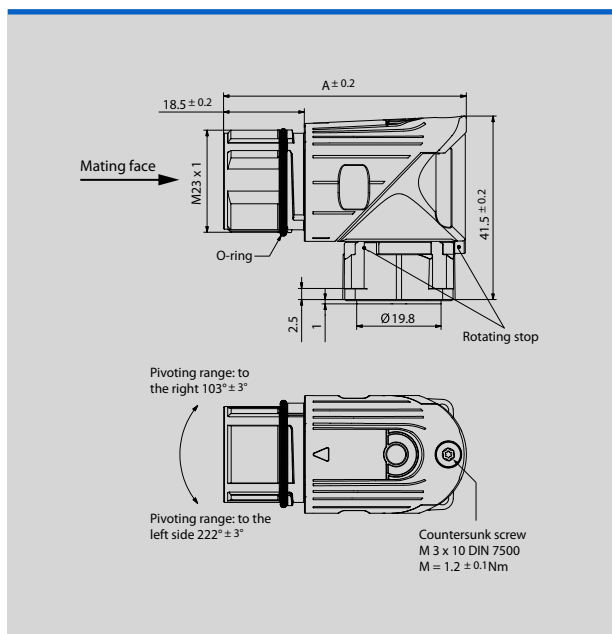

17-pole
17 x Ø 1 mm, 0° coded

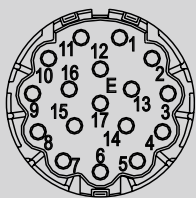

17-pole
17 x Ø 1 mm, 0° coded

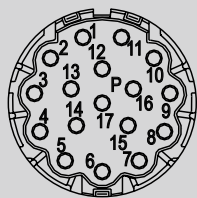

Intercomtec type designation
ASTA 014 NN00 41 0100 000
(Cable clamping range
6-10 mm)

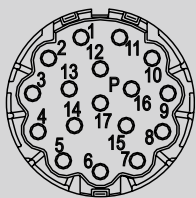

Intercomtec type designation
ASTA 014 NN00 41 0100 000
(Cable clamping range
6-10 mm)

Mating connector

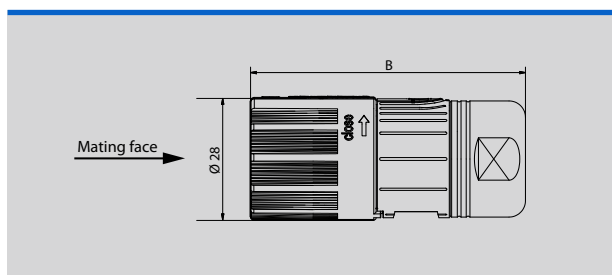

Connector type	A	B
Signal	55.6	59
Power	55.3	78

Configuration Options

Single Cable Motor Connector, I-Tec



Power / Signal

Pin	Function
A	U
B	V
C	W
Grounding	PE
1	US (DSL +)
2	GND (DSL -)
3	Brake +*
4	Brake -*
5	-

Motor connector

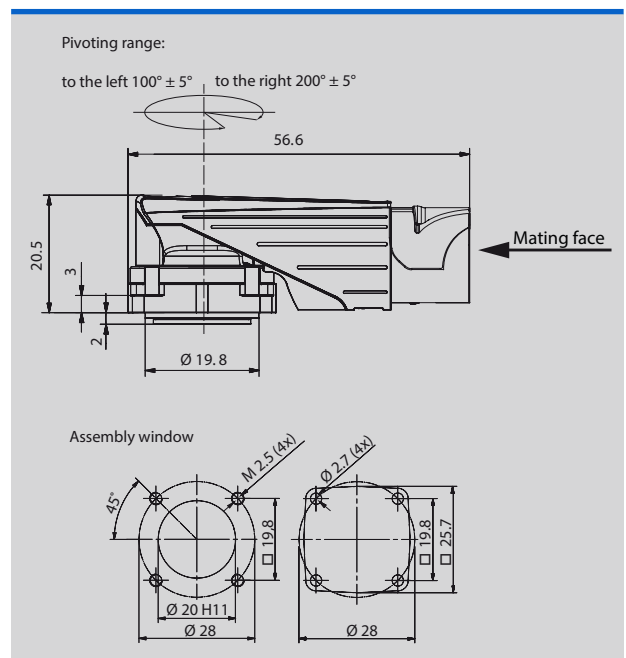

Motor connector

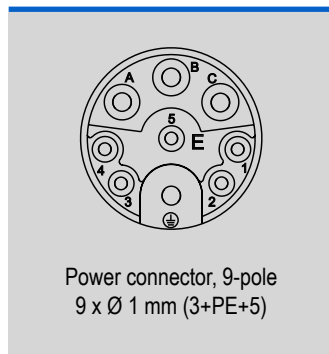

Mating connector

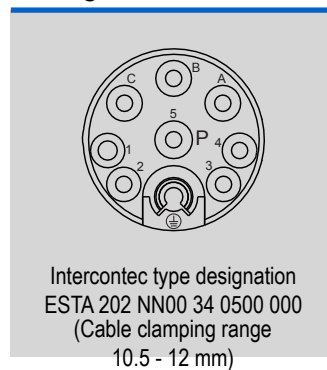

* if available

Mating connector

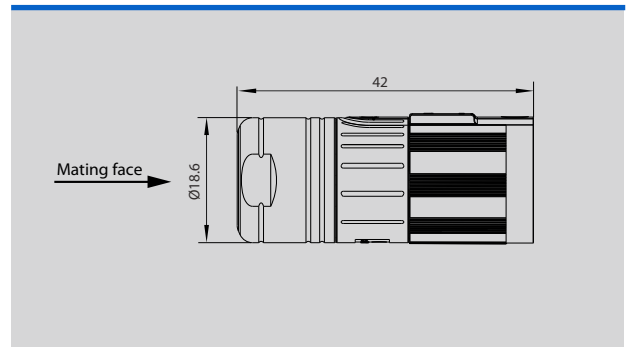

Single Cable Motor Connector, M23



Power / Signal

Pin	Function
A	Brake + *
B	Brake - *
C	Us (DSL+)
D	GND (DSL-)
1	U
4	V
3	W
Grounding	PE

Motor connector

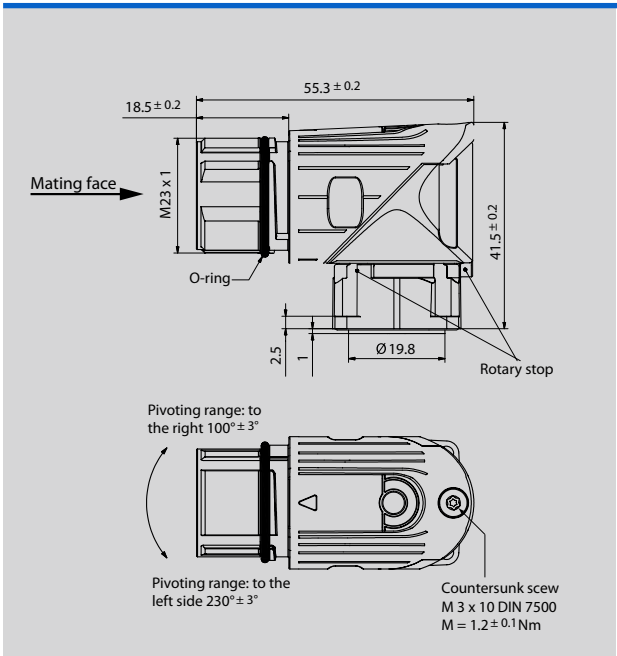

Motor connector

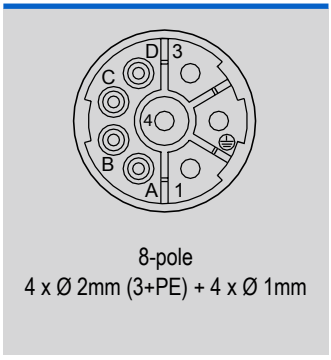

Mating connector

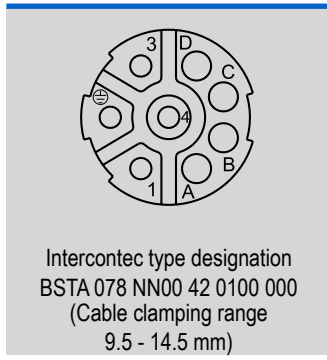

* if available

Mating connector

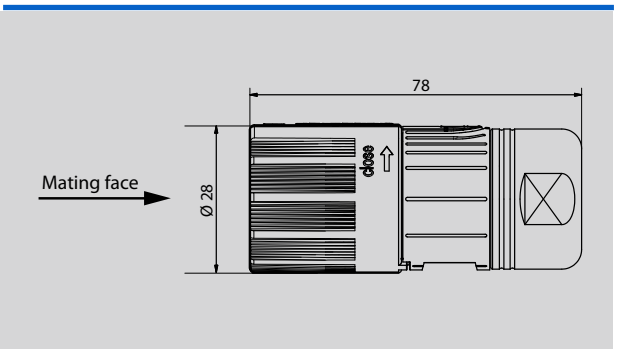



Allied Motion Technologies Inc.
495 Commerce Dr,
Amherst, NY 14228 USA

North America
+1 (716) 242-7535
inquiry@alliedmotion.com

Europe (EMEA)
+46 (8) 546 111 00
inquiry.eu@alliedmotion.com

Asia
+852 2607 4038
inquiry@alliedmotion.com