

# Brushless Motor with Integral Drive

## EnduraMax 95i Series

### 95 mm (3.77 inch) NEMA 34 BLDC Motor with Integrated Digital Drive

Allied Motion's EnduraMax 95i series motors are 95 mm (3.77 in) diameter NEMA 34 brushless DC motors incorporating an integrated drive with both CANopen and Modbus networking. These motors can control torque, speed and/or position in a broad range of applications such as valve actuators, rotary and linear actuators, conveyor drives, AGV vehicle traction or steering, and similar commercial/ industrial applications.

Compared to a brush DC motor, the EnduraMax 95i features quieter operation, longer service life, and no need of brush maintenance, making it the right choice to replace DC motors in equipment modernizations and in new designs.

#### Options & Accessories

- Alternate winding voltage
- Integral holding brake
- Connectorized cable sets
- Tailored winding designs to optimize performance
- Sealed ball bearings
- Stainless steel shaft
- IP67 protection level
- Customized shaft, and/or mounting to match application requirements
- Automotive-class protection against over-voltage, voltage reversal



#### Features & Benefits

- Standard NEMA 34 interface and shaft design
- Three standard stack lengths with rated continuous output power up to 750 W
- Continuous rated torque of up to 2.4 Nm (340 oz-in) and rated speed of up to 5000 RPM
- All-digital integrated drive for precise motor control
- Standard 12, 24 or 48 VDC winding voltage selection – ideal for battery-powered applications
- 1/2-inch (50.8 mm) cold-rolled steel shaft
- Heavy-duty ball bearings
- Both Modbus and isolated CANopen bus interfaces – “keyswitch” power enable mode using CAN port
- Command inputs:  $\pm 10$  VDC, 4 - 20 mA, CANopen or Modbus bus
- Second analog input, 4 - 20 mA compatible
- Integrated magnetic encoder with 4096 cpr effective resolution (not available externally)
- PC-based IN Control HMI software simplifies drive setup and tuning
- RS-232 setup port
- Programmable I/O: 6 inputs and 3 outputs
- Position indexing capability via communications bus or input trigger
- IP50 environmental protection level
- Class F (155 °C) rated winding





#### QuickShip Products

Some of the part number configurations for this product are in stock and available for ***immediate delivery!***

Look for the QuickShip symbol next to available part numbers. Then, click on the part number to go directly to our online store.



## EnduraMax 95i 2-Stack Models – Specifications

Model		 <b>EMI-095Q2000</b>	 <b>EMI-095R2002</b>	 <b>EMI-095R2003</b>	 <b>EMI-095G2002</b>	 <b>EMI-095G2003</b>
DC Input Voltage		12 VDC	24 VDC		48 VDC	
Type			Low Speed	High Speed	Low Speed	High Speed
Rated Torque Nm (oz.in.)	Standard Models	0.49 (69)	0.79 (113)	0.49 (70)	0.89 (127)	0.74 (105)
	Fan-cooled Models	0.78 (111)	0.92 (131)	0.64 (91)	0.94 (134)	0.84 (120)
	Peak <sup>(1)</sup>	1.20 (170)	2.12 (300)	1.48 (210)	2.12 (300)	2.12 (300)
Rated Speed (RPM)	Standard Models	3425	2800	5000	2700	4900
	Fan-cooled Models	2960	2600	4700	2650	4800
No-load Speed (RPM)		3915	3500	5750	3350	5800
Rated Power <sup>(2)</sup> W (HP)	Standard Models	170 (0.23)	235 (0.31)	260 (0.34)	250 (0.33)	380 (0.50)
	Fan-cooled Models	240 (0.32)	250 (0.33)	315 (0.42)	265 (0.35)	425 (0.56)
DC Input Current (ADC)	Standard Models	18.4	12.6	13.4	7.2	9.8
	Fan-cooled Models	29.0	14.5	17.1	7.7	11.1
Thermal Resistance (°C/W)		2.23	1.17	1.33	0.97	1.28
Power Derating Factor W/°C (W/°F)		1.23 (0.69)	1.33 (0.74)	2.36 (1.31)	1.09 (0.61)	4.67 (2.60)
Motor Rotor Inertia E-5 kg·m <sup>2</sup> (oz·in·sec <sup>2</sup> )		6.10 (0.0086)				
Brake Inertia E-5 kg·m <sup>2</sup> (oz·in·sec <sup>2</sup> )		0.27 (0.0004) additional inertia with brake option				
Weight kg (lb)	Complete	1.40 (3.10)				
	Brake Only	0.15 (0.33)				
Amplifier Type	PWM (20 kHz) 4-quadrant control					
Current (Torque) Loop Type	DQ PI, 100 μs update time					
Velocity Loop	PID / PDF 200 μs update time					
Position Loop	PFF, 500 μs update time (position control through CANopen or Modbus channel only)					
Analog Inputs	Primary: ±10 VDC, 10 kΩ, 12-bit resolution; Secondary: 4 - 20 mA compatible, ±10 VDC, 12-bit resolution, 500 Ω					
Analog Output	0 - 3.3 V, 10 mA max.					
Setup Port	RS-232, 460 kBd for setup and tuning using IN Control software on a PC					
Bus Port	Isolated CANopen or Modbus RTU, two-wire, half-duplex over RS-485 • CANopen isolated supply voltage: 8—32 VDC • CAN V+ terminal must have voltage applied to activate drive; drive current consumption < 100 μA in inactive state					
Digital I/O	• 6 inputs (e.g. CW, CCW limits, Enable): +3 to +60 V (high); 0 to 0.5 V (low) at 3 mA nominal draw • 3 outputs (e.g. Fault): open collector, +60 V max., 100 mA max. sink					
Encoder	• Type: Magnetic, integrated • Effective resolution: 4096 cpr • Accuracy: ±0.5 degree					
Protection Features	• Over voltage detection • Short-circuit and reverse polarity protection • I <sup>2</sup> T current foldback • Drive over-temperature • IP50, (IP67 optional)					
Ambient Storage Temperature	-40 to 125 °C (-40 to 257 °F)					



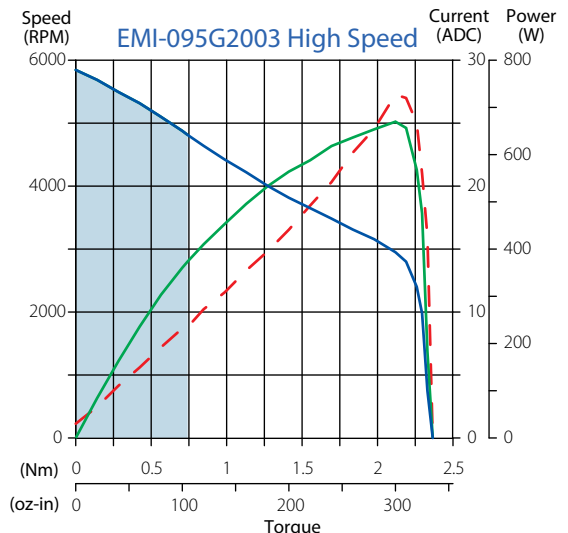
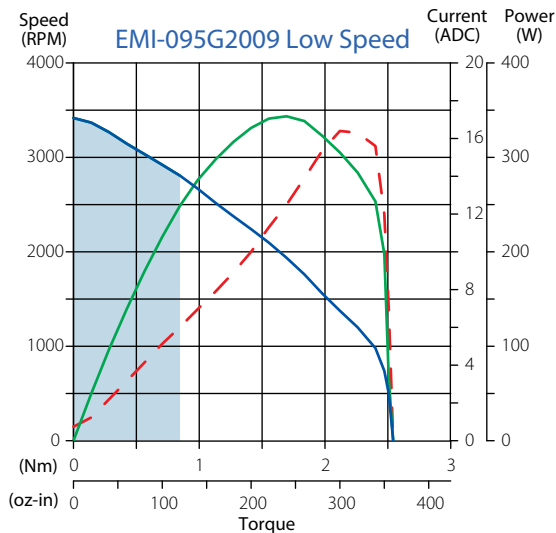
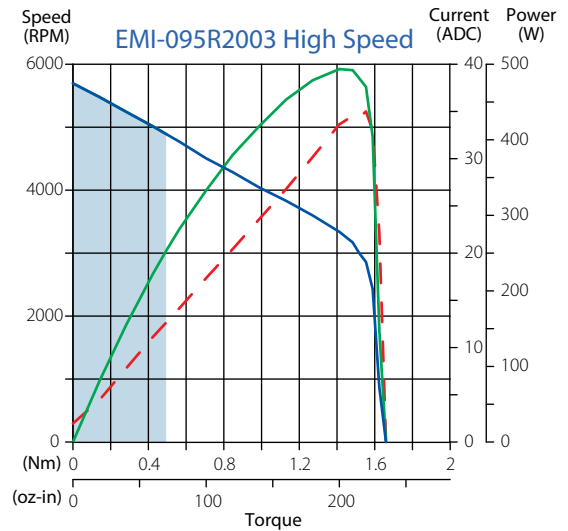
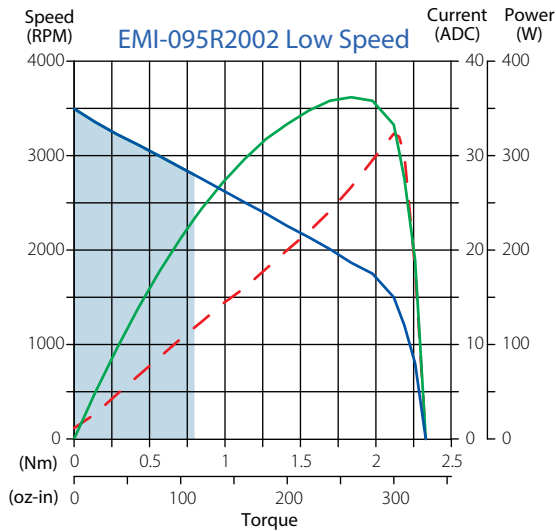
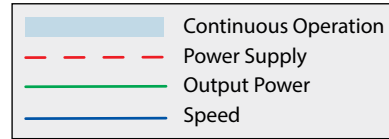
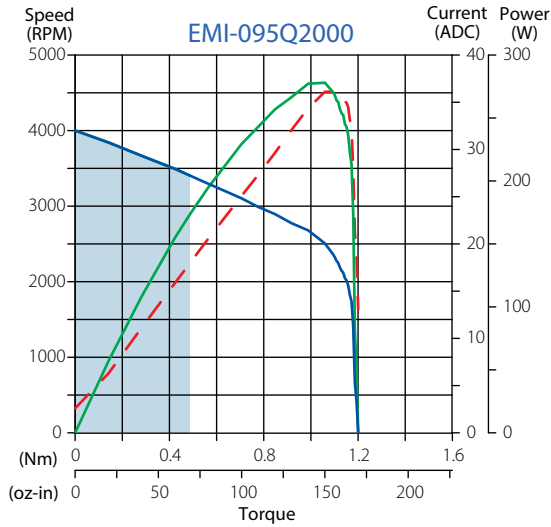

(1) Maximum of 4 sec.

(2) With motor mounted to aluminum plate 200 x 200 x 10 mm (8 x 8 x 0.375 in) at 23 °C (derate motor power above 23 °C ambient temperature)

## EnduraMax 95i 2-Stack Models – Performance



## EnduraMax 95i 6-Stack Models – Specifications

Model		EMI-095Q6000	 EMI-095R6003	 EMI-095R6004	 EMI-095G6003	 EMI-095G6004
DC Input Voltage		12 VDC	24 VDC		48 VDC	
Type			Low Speed	High Speed	Low Speed	High Speed
Rated Torque Nm (oz.in.)	Standard Models	0.61 (87)	1.35 (192)	0.76 (108)	1.35 (192)	1.09 (155)
	Fan-cooled Models	1.03 (146)	1.61 (228)	1.30 (185)	1.83 (260)	1.51 (214)
	Peak <sup>(1)</sup>	1.50 (240)	3.53 (500)	2.05 (290)	3.81 (540)	3.81 (540)
Rated Speed (RPM)	Standard Models	2825	1800	4100	2300	4050
	Fan-cooled Models	2515	1700	3750	2050	3850
No-load Speed (RPM)		3105	2200	4450	2700	4450
Rated Power <sup>(2)</sup> W (HP)	Standard Models	180 (0.24)	255 (0.34)	330 (0.44)	330 (0.44)	465 (0.62)
	Fan-cooled Models	270 (0.36)	285 (0.38)	510 (0.68)	395 (0.52)	610 (0.81)
DC Input Current (ADC)	Standard Models	18.9	13.7	16.3	8.8	11.4
	Fan-cooled Models	30.9	16.5	27.1	11.5	15.5
Thermal Resistance (°C/W)		1.67	1.00	1.56	1.15	1.68
Power Derating Factor W/°C (W/°F)		1.48 (0.82)	1.85 (1.03)	3.98 (2.21)	2.95 (1.64)	7.38 (4.10)
Motor Rotor Inertia E-5 kg·m <sup>2</sup> (oz·in·sec <sup>2</sup> )			1.17 (0.0166)			
Brake Inertia E-5 kg·m <sup>2</sup> (oz·in·sec <sup>2</sup> )			0.27 (0.0004) additional inertia with brake option			
Weight kg (lb)	Complete		2.10 (4.50)			
	Brake Only		0.15 (0.33)			
Amplifier Type		PWM (20 kHz) 4-quadrant control				
Current (Torque) Loop Type		DQ PI, 100 μs update time				
Velocity Loop		PID / PDF 200 μs update time				
Position Loop		PFF, 500 μs update time (position control through CANopen or Modbus channel only)				
Analog Inputs		Primary: ±10 VDC, 10 kΩ, 12-bit resolution; Secondary: 4 - 20 mA compatible, ±10 VDC, 12-bit resolution, 500 Ω				
Analog Output		0 - 3.3 V, 10 mA max.				
Setup Port		RS-232, 460 kBd for setup and tuning using IN Control software on a PC				
Bus Port		Isolated CANopen or Modbus RTU, two-wire, half-duplex over RS-485 • CANopen isolated supply voltage: 8—32 VDC • CAN V+ terminal must have voltage applied to activate drive; drive current consumption < 100 μA in inactive state				
Digital I/O		• 6 inputs (e.g. CW, CCW limits, Enable): +3 to +60 V (high); 0 to 0.5 V (low) at 3 mA nominal draw • 3 outputs (e.g. Fault): open collector, +60 V max., 100 mA max. sink				
Encoder		• Type: Magnetic, integrated • Effective resolution: 4096 cpr • Accuracy: ±0.5 degree				
Protection Features		• Over voltage detection • Short-circuit and reverse polarity protection • I <sup>2</sup> T current foldback • Drive over-temperature • IP50, (IP67 optional)				
Ambient Storage Temperature		-40 to 125 °C (-40 to 257 °F)				



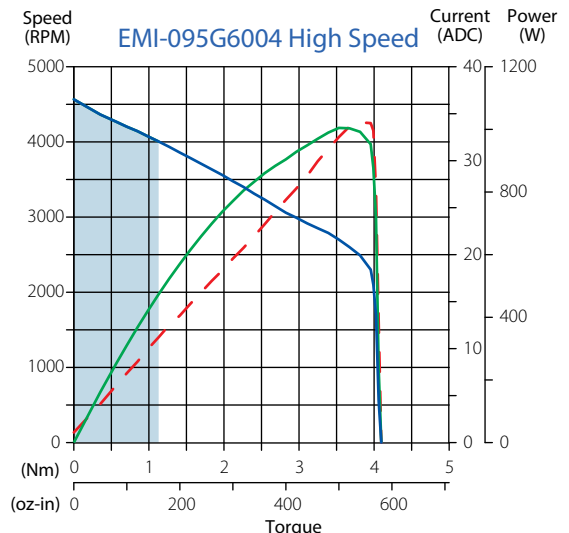
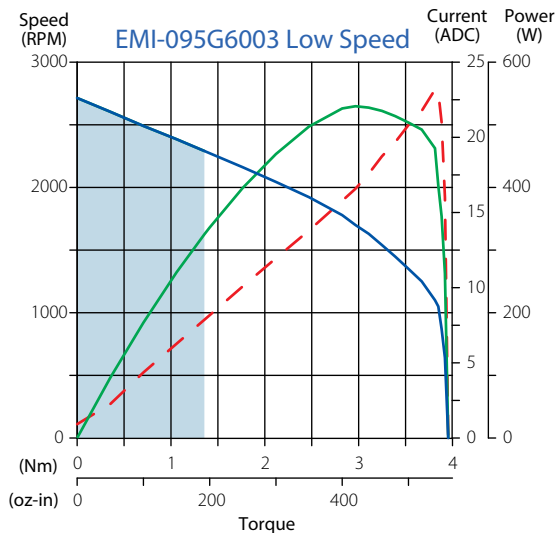
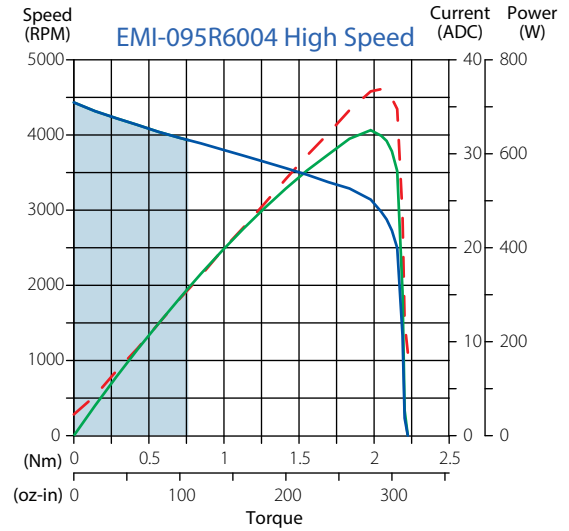
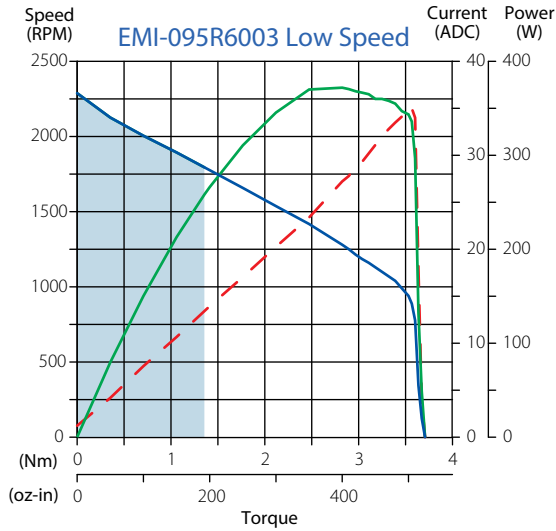
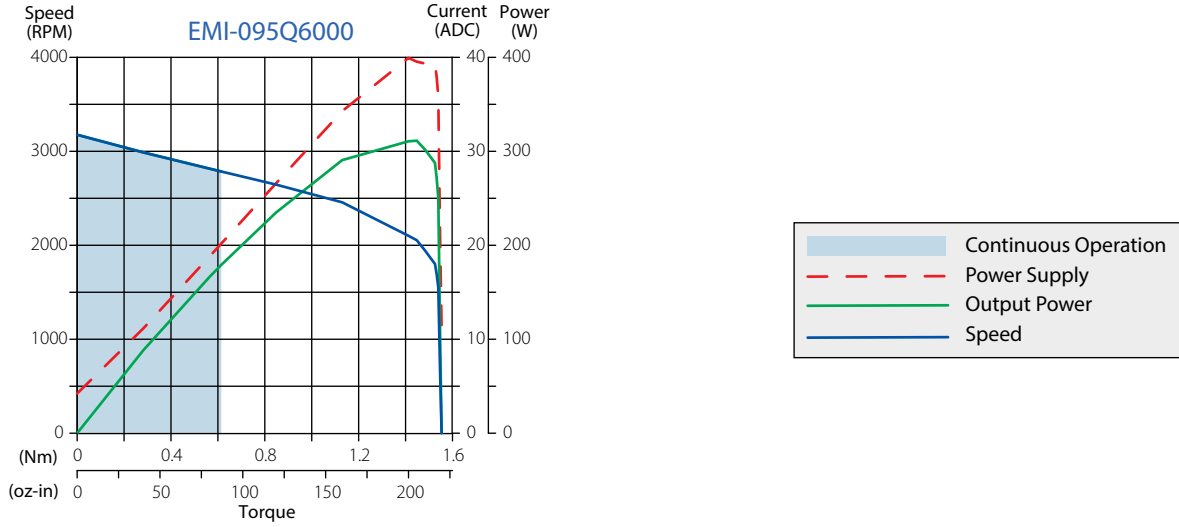

(1) Maximum of 4 sec.

(2) With motor mounted to aluminum plate 200 x 200 x 10 mm (8 x 8 x 0.375 in) at 23 °C (derate motor power above 23 °C ambient temperature)

# EnduraMax 95i 6-Stack Models – Performance



## EnduraMax 95i 9-Stack Models – Specifications

Model		EMI-095Q9000	 EMI-095R9003	 EMI-095R9004	 EMI-095G9003	 EMI-095G9004
DC Input Voltage		12 VDC	24 VDC		48 VDC	
Type			Low Speed	High Speed	Low Speed	High Speed
Rated Torque Nm (oz.in.)	Standard Models	0.66 (94)	1.55 (220)	1.00 (143)	1.89 (268)	1.38 (196)
	Fan-cooled Models	1.19 (169)	2.06 (292)	1.70 (242)	2.23 (317)	2.40 (340)
	Peak <sup>(1)</sup>	1.70 (250)	3.78 (535)	2.58 (365)	3.81 (540)	3.88 (550)
Rated Speed (RPM)	Standard Models	2570	1650	3250	1700	3200
	Fan-cooled Models	2310	1500	3000	1600	2950
No-load Speed (RPM)		2790	3500	3450	1950	3450
Rated Power <sup>(2)</sup> W (HP)	Standard Models	175 (0.24)	270 (0.36)	340 (0.45)	335 (0.44)	470 (0.63)
	Fan-cooled Models	285 (0.38)	330 (0.44)	535 (0.71)	375 (0.50)	750 (1.00)
DC Input Current (ADC)	Standard Models	18.8	14.0	16.9	9.1	11.4
	Fan-cooled Models	35.2	18.6	27.8	10.8	19.6
Thermal Resistance (°C/W)		1.31	0.97	1.43	0.96	1.56
Power Derating Factor W/°C (W/°F)		1.50 (0.83)	2.24 (1.25)	4.22 (2.34)	2.18 (1.21)	7.66 (4.26)
Motor Rotor Inertia E-5 kg·m <sup>2</sup> (oz·in·sec <sup>2</sup> )			1.73 (0.0245)			
Brake Inertia E-5 kg·m <sup>2</sup> (oz·in·sec <sup>2</sup> )			0.27 (0.0004) additional inertia with brake option			
Weight kg (lb)	Complete		1.40 (3.10)			
	Brake Only		0.15 (0.33)			
Amplifier Type		PWM (20 kHz) 4-quadrant control				
Current (Torque) Loop Type		DQ PI, 100 μs update time				
Velocity Loop		PID / PDF 200 μs update time				
Position Loop		PFF, 500 μs update time (position control through CANopen or Modbus channel only)				
Analog Inputs		Primary: ±10 VDC, 10 kΩ, 12-bit resolution; Secondary: 4 - 20 mA compatible, ±10 VDC, 12-bit resolution, 500 Ω				
Analog Output		0 - 3.3 V, 10 mA max.				
Setup Port		RS-232, 460 kBd for setup and tuning using IN Control software on a PC				
Bus Port		Isolated CANopen or Modbus RTU, two-wire, half-duplex over RS-485 • CANopen isolated supply voltage: 8—32 VDC • CAN V+ terminal must have voltage applied to activate drive; drive current consumption < 100 μA in inactive state				
Digital I/O		• 6 inputs (e.g. CW, CCW limits, Enable): +3 to +60 V (high); 0 to 0.5 V (low) at 3 mA nominal draw • 3 outputs (e.g. Fault): open collector, +60 V max., 100 mA max. sink				
Encoder		• Type: Magnetic, integrated • Effective resolution: 4096 cpr • Accuracy: ±0.5 degree				
Protection Features		• Over voltage detection • Short-circuit and reverse polarity protection • I <sup>2</sup> T current foldback • Drive over-temperature • IP50, (IP67 optional)				
Ambient Storage Temperature		-40 to 125 °C (-40 to 257 °F)				

(1) Maximum of 4 sec.

(2) With motor mounted to aluminum plate 200 x 200 x 10 mm (8 x 8 x 0.375 in) at 23 °C (derate motor power above 23 °C ambient temperature)

## EnduraMax 95i 9-Stack Models – Performance

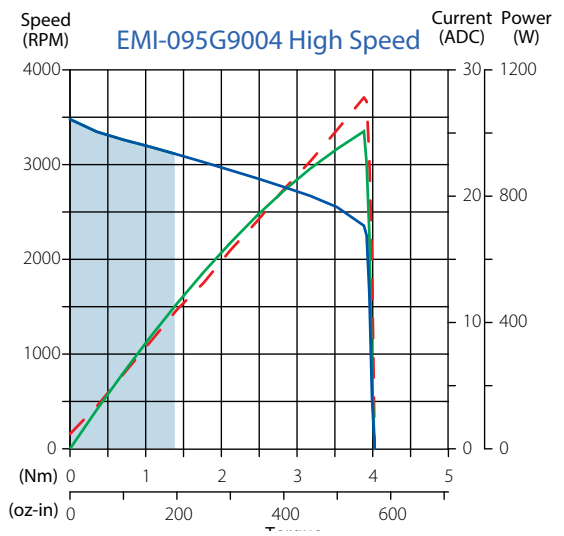
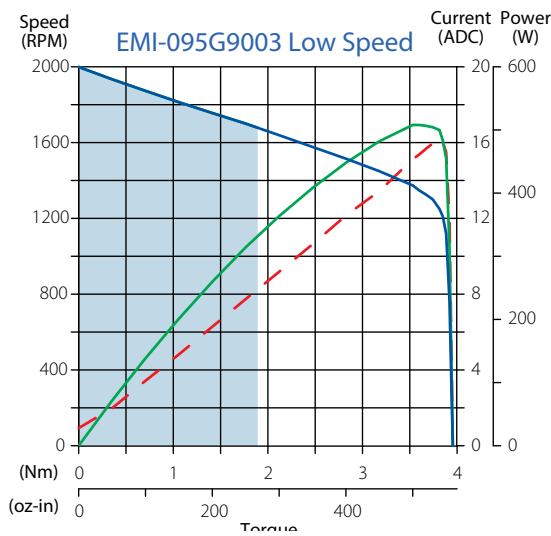
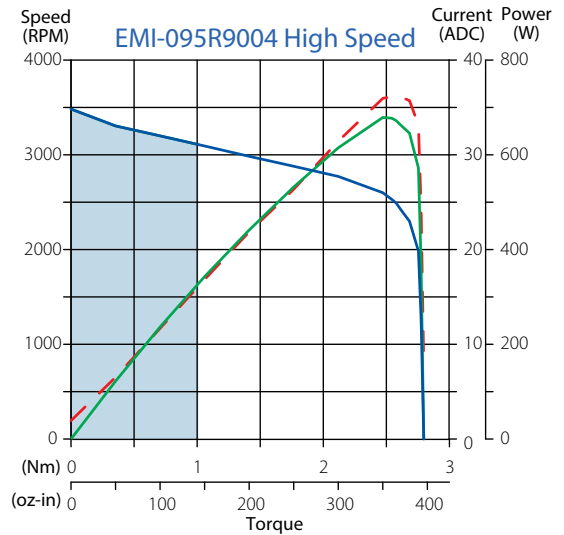
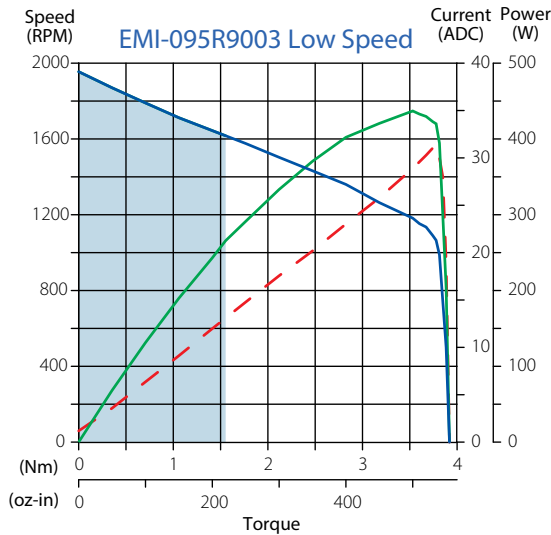
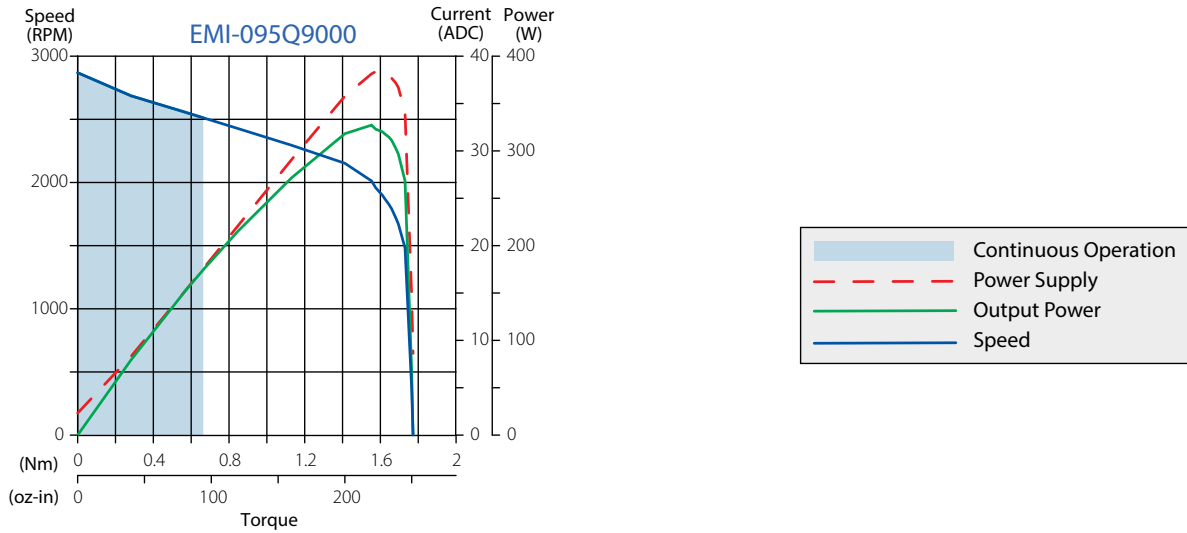

**EnduraMax 95i Dimensions — mm (in)**

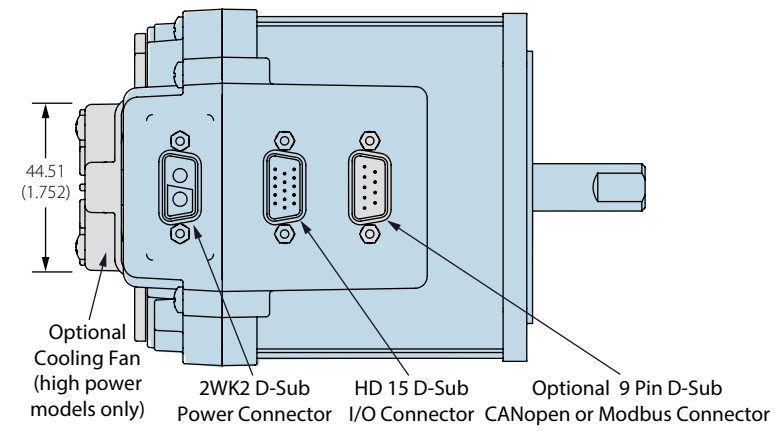

	Length A	(w/brake option)
<u>2-stack models</u>	89.2 (3.51)	131.1 (5.16)
<u>6-stack models</u>	108.2 (4.26)	150.2 (5.91)
<u>9-stack models</u>	127.3 (5.01)	169.2 (6.66)

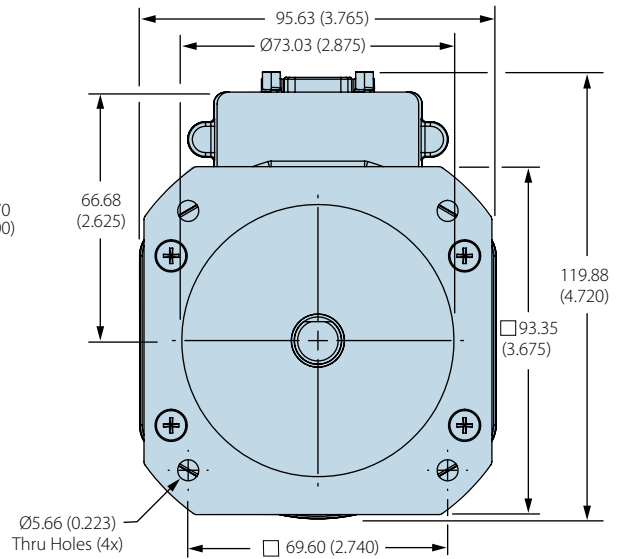
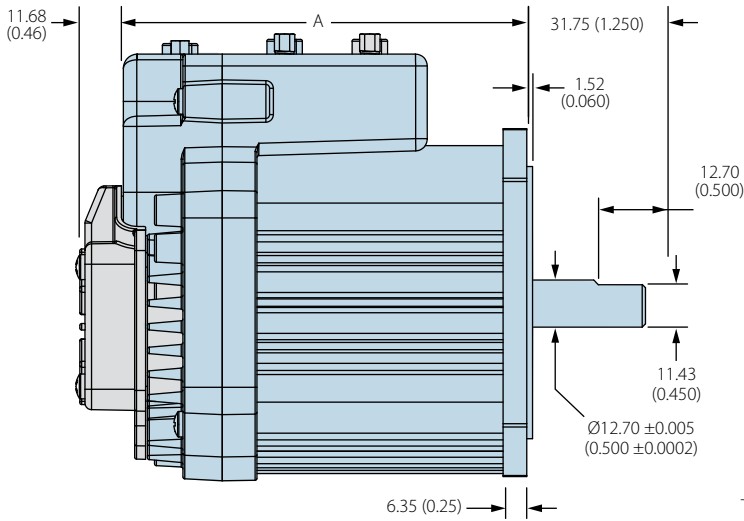

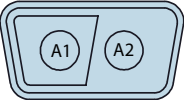

## EnduraMax 95i Electrical Connections

Motor Power (J1)		Pin	Function
		1	DC Power (-)
		2	DC Power (+)
<b>Mate:</b>		Konmek PS400N-2WK2FTB0	
<b>Sealed Mate:</b>		Konmek PS400N-2WK2FTB0 w/HW1-1 shroud	

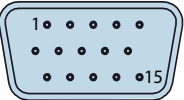
User I/O (J2)		Pin	Function
		1	Input 1
		2	Input 2
		3	Input 3
		4	Input 4
		5	Analog Input 1 (+)
		6	Input 5
		7	Input 6
		8	RS232 Rx / RS485 (-)
		9	Output 1
		10	Analog Input 1 (-)
		11	Output 2
		12	Output 3
		13	RS232 Tx / RS485 (+)
		14	Common
		15	Analog Output
<b>Mate:</b>		Konmek HS0-15FTB0	
<b>Sealed Mate:</b>		Konmek HS0-15FTB0 w/HW1-1 shroud	

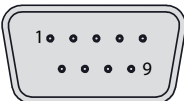
CANopen or Modbus (J3 Option)		Pin	Function
		1	Analog 2 IN / Modbus COMMON
		2	CANL
		3	CAN COM
		4	Modbus Tx / Rx (-)
		5	—
		6	Analog 2 IN (+)
		7	CANH
		8	Modbus Tx / Rx (+)
		9	CANV+
<b>Mate:</b>		Konmek DS0-09FTB0	
<b>Sealed Mate:</b>		Konmek DS0-09FTB0 w/HW1-1 shroud	

## EnduraMax 75i Cables & Connector Accessories

	Description	Part Number
<b>I/O Cables</b>	I/O Lead Assembly, 1 m, female 15-pin D-Sub to 9-pin D-sub	AC-CB-822001
	CAN Lead Assembly, 1 m, female 9-pin D-Sub to 6.4 mm strip	AC-CB-822004
	CAN Lead Assembly, 1 m, female 9-pin D-Sub to 6.4 mm strip, seal/shield	AC-CB-822014
	CAN Lead Assembly, 3 m, female 9-pin D-Sub to 6.4 mm strip	AC-CB-822005
	CAN Lead Assembly, 3 m, female 9-pin D-Sub to 6.4 mm strip, seal/shield	AC-CB-822015
	1 m, 15-pin D-Sub to 6.4 mm strip	AC-CB-822002
	1 m, 15 pin D-Sub to 6.4 mm strip, seal shield	AC-CB-822012
	3 m, 15-pin D-Sub to 6.4 mm strip	AC-CB-822003
	3 m, 15-pin D-Sub to 6.4 mm strip, seal/shield	AC-CB-822013
	<b>Power Cables</b>	Power Lead Assembly, 1 m, Konmek power D-Sub 2-wire, 10 gauge, sealed
Power Lead Assembly, 3 m, Konmek power D-Sub 2-wire, 10 gauge, sealed		AC-CB-822011
1 m, D-Sub 2-wire, 10 gauge, to flying leads		AC-CB-822006
1 m, D-Sub 2-wire, 14 gauge, to flying leads		AC-CB-822008
1 m, D-Sub 2-wire, 10 gauge, seal/shield		AC-CB-822016
3 m, D-Sub 2-wire, 10 gauge, to flying leads		AC-CB-822007
<b>Connector Kits</b>	3 m, D-Sub 2-wire, 14 gauge, to flying leads	AC-CB-822009
	3 m, D-Sub 2 wire, 14 gauge, seal/shield	AC-CB-822017
	15 pin, (2) 9-pin, 2-pin power D-Sub + hoods	AC-CK-100103
<b>USB to RS232</b>	15 pin, (2) 9-pin, 2-pin power D-Sub + hoods, sealed	AC-CK-100105
	USB to high speed RS232, 1.75 m cable	AC-CB-100104
<b>IP67 Cover</b>	For unused D-Sub connector	AC-CK-100114

## Documents & Software

Documentation and most software are available for download from the [Allied Motion website \(www.alliedmotion.com\)](http://www.alliedmotion.com)

<b>34-21001</b>	Hardware Manual: Wiring and Installation (PDF)
<b>34-22001</b>	Software Manual: IN Control User Guide (PDF)
<b>34-2202</b>	Software Manual: Parameters and Control Structure (PDF) + (Attachment A) Sortable Parameters and Variables List (Excel file)
—	ALLNET .NET Framework software

## Custom & Specific-Purpose Products & Sub-Assemblies

Allied Motion offers a very wide selection of standard motion control solutions to satisfy the requirements found in the commercial, industrial and aerospace and defense markets. And, we are adding new products every year to meet new demands we find in those markets.

However, a recognized strength of Allied Motion is our willingness and ability to develop custom motion control products and systems to meet the specific needs of customers. Please contact us to discuss your specialized application requirements.

## Allied Motion Solution Centers

Allied Motion maintains Solution Centers in three geographically strategic locations to assist our customers with all aspects of their product selection and buying decisions. These facilities assure local support no matter your location around the globe.

Each Solution Center's experienced application engineering and customer service team provide:

- Application analysis assistance
- Detailed product information and documentation
- Standard product selection
- Product customization and options guidance
- Specification development assistance for custom-design products
- Price quotations
- Ordering, order status and shipment information
- Logistics assistance

For assistance with your project, contact us at one of our continental Allied Motion Solution Centers listed below.

Allied Motion also has a global network of factory trained selling partners to serve you. Visit our website for contact information for the Allied Motion Sales Partner nearest you.



## High-Performance Specialty Motors & Application-Specific Motion Systems

Aerospace & Defense  
Automation  
Commercial-Consumer  
Industrial  
Medical  
Pumps  
Robotics  
Vehicles

[www.alliedmotion.com](http://www.alliedmotion.com)

## North America

United States, Canada, Mexico:

### Allied Motion Technologies NASC

495 Commerce Drive, Ste 3  
Amherst, NY 14228 USA

+1 (716) 242-7535

[inquiry@alliedmotion.com](mailto:inquiry@alliedmotion.com)

## Europe

UK, Ireland, continental Europe,  
Eastern Europe, Scandinavia, Israel:

### Allied Motion Technologies EUSC

Ekbacksvägen 26, PO Box 11198  
S-161 11 Bromma, Sweden

+46 (8) 546 111 00

[inquiry@alliedmotion.com](mailto:inquiry@alliedmotion.com)

## Asia

China, Taiwan, Japan, S. Korea, and  
other Far East Countries:

### Allied Motion Technologies ASC

58 Leshan Road  
Xinbei District, Changzhou 213022  
China

+852 2607 4038 +86 519 85113625

[inquiry@alliedmotion.com](mailto:inquiry@alliedmotion.com)